

INSTALLATION INSTRUCTIONS

STHS200 SPRING TENSION HOLDING SYSTEM

USE ASTA DOOR CORPORATION PARTS ONLY - ALL OTHERS SHALL VOID WARRANTY

WARNING

1. SPRING ADJUSTMENT MUST BE DONE WHILE DOOR IS LOCKED IN THE FULLY OPEN POSITION.
2. NEVER OPERATE THE DOOR IF THE SET SCREWS ARE NOT FULLY TIGHTENED ON BOTH STHS AXLE SUPPORTS. FAILURE TO DO SO COULD RESULT IN SERIOUS INJURY.
3. THE DOOR TENSION MUST BE FULLY TRANSFERRED TO THE PIPE WRENCH BEFORE LOOSENING THE SET SCREWS ON THE STAMPED AXLE SUPPORT OR RELEASING THE TENSION ON THE STHS TENSION ADJUSTMENT DEVICE. NEVER FORCE THE SPRING PIN. TENSION MUST BE RELEASED FROM THE DEVICE BEFORE PUSHING ON THE SPRING PIN. FAILURE TO DO SO COULD RESULT IN SERIOUS INJURY.
4. WHEN ADJUSTING TENSION, THE TORQUE LOAD IS MAINTAINED BY THE FRICTION BETWEEN THE SHAFT AND THE CAM OF THE STHS TENSION DEVICE. DO NOT MODIFY THE FRICTION COEFFICIENT BY OILING, PAINTING OR ALTERING THE SURFACE FINISH OF THE SHAFT. FAILURE TO FOLLOW THOSE INSTRUCTIONS COULD CAUSE THE SHAFT TO SLIP AND RESULT IN SERIOUS INJURY.
5. WHEN OPENED THE STHS SPRING TENSION DEVICE IS UNDER GREAT SPRING TENSION. GENTLY RELEASE THE SPRING PIN TO AVOID GETTING YOUR HAND CAUGHT IN THE SYSTEM. FAILURE TO DO SO COULD RESULT IN SERIOUS INJURY.

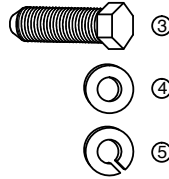
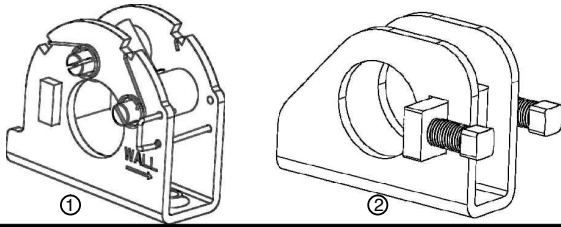

PARTS LIST			
ITEM #	PART #	ITEM DESCRIPTION	QTY.
1	420117-1	STHS, 1- 5/16" TENSION AXLE SUPPORT	VARIES
2	420116-1	SAS, 1- 5/16" STAMPED AXLE SUPPORT	VARIES
3	730804-1	BOLT, 3/8" - 16 x 3/4" HEX HEAD	4
4	750103-1	WASHER, 3/8" FLAT	4
5	750203-1	WASHER, 3/8" LOCK	4

IF SUPPLIED THIS HARDWARE WILL BE USED IN LIEU OF AXLE HARDWARE SHOWN ON STEP #5, DIAGRAM #17 OF THE DOOR INSTALLATION INSTRUCTIONS.

STEP #1 - LOCK THE STHS TENSION AXLE SUPPORT IN OPEN POSITION. (IF SUPPLIED)

A) PULL THE LOCK PIN.

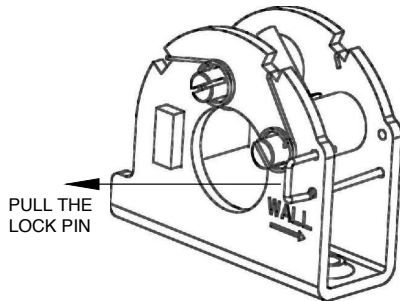

B) PUSH THE SPRING PIN BACKWARD.

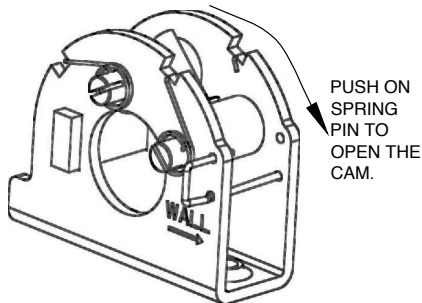

C) LOCK THE STHS CAM IN OPEN POSITION BY PUSHING THE LOCK PIN ON THE SPRING PIN.

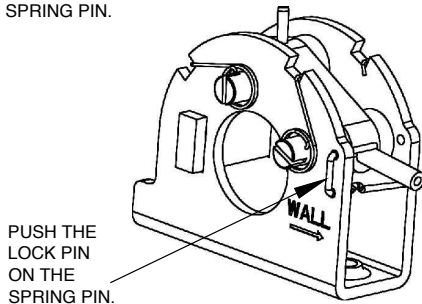

STEP #2 - INSTALL THE STHS TENSION AXLE SUPPORT AND STAMPED AXLE SUPPORT ONTO THE SHAFT.

A) SLIDE THE STHS TENSION AXLE SUPPORT AND THE STAMPED AXLE SUPPORT ONTO THE SHAFT. BE SURE TO INSTALL THE STHS AND STAMPED AXLE SUPPORT IN THE PROPER POSITIONS BY FOLLOWING THE INDICATION "WALL" ON THE PARTS. *

B) RAISE DOOR ONTO SUPPORT BRACKETS & FASTEN SECURELY WITH HARDWARE FASTENERS PROVIDED

*IF A 2ND STAMPED AXLE SUPPORT IS PROVIDED IN LIEU OF THE TENSION AXLE SUPPORT INSTALL ACCORDINGLY

C) TIGHTEN SET SCREWS & PRETENSION DOOR AS DESCRIBED IN STEP #6 OF THE STANDARD DOOR INSTALLATION INSTRUCTIONS.

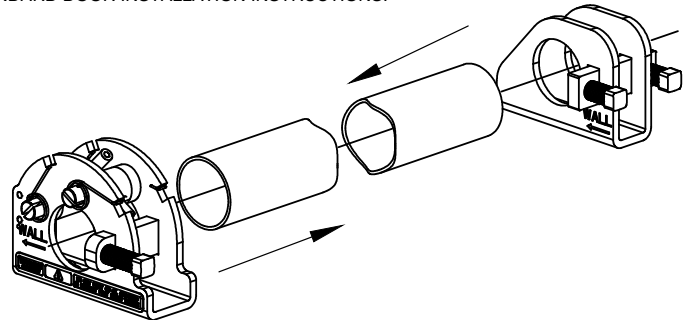

D) PULL THE LOCK PIN TO RELEASE THE SPRING PIN, WHICH WILL ALLOW THE STHS TENSION AXLE SUPPORT TO GRIP THE SHAFT.

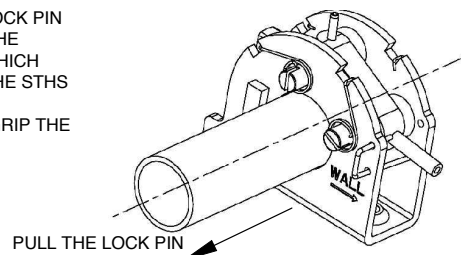

CAUTION: WHEN OPENED, THE STHS TENSION AXLE SUPPORT IS UNDER GREAT SPRING TENSION. GENTLY RELEASE THE SPRING PIN TO AVOID GETTING YOUR HAND CAUGHT IN SYSTEM. FAILURE TO DO SO COULD RESULT IN SERIOUS INJURIES

E) FOLLOW SPRING PRETENSION PROCEDURE AS SHOWN IN STEPS OF THE DOOR INSTALLATION INSTRUCTIONS

NOTICE: THE STHS IS A ONE-WAY MECHANICAL DEVICE. IT ALLOWS YOU TO WIND THE SPRING BUT BLOCK THE TORQUE LOAD IN THE UNWINDING DIRECTION.

⚠ WARNING

SPRING ADJUSTMENT MUST BE DONE WHILE THE DOOR IS LOCKED IN ITS OPEN POSITION. FAILURE TO DO SO COULD RESULT IN SERIOUS INJURIES.

STEP #3 - ADJUST THE TENSION ON THE SPRINGS.

A) TRANSFER SPRING LOAD TO A PIPE WRENCH, THEN LOOSEN SET SCREWS ON BOTH AXLE SUPPORTS

B) USING A PIPE WRENCH OR OTHER MECHANICAL DEVICE, ROTATE THE SHAFT TO APPLY TENSION TO THE DOOR. BY RELEASING THE TENSION FROM THE PIPE WRENCH, THE STHS WILL GRIP ON TO THE SHAFT AND KEEP THIS NEW LOCATION.

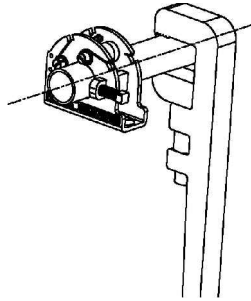

C) WHEN THE FINAL TORQUE LOAD IS REACHED, SECURELY LOCK THE SYSTEM BY TIGHTENING THE SET SCREWS ON THE STHS TENSION AXLE SUPPORT AND SAS STAMPED AXLE SUPPORT. SET SCREWS MUST BE TIGHTENED BETWEEN 20 AND 25 FT-LB.

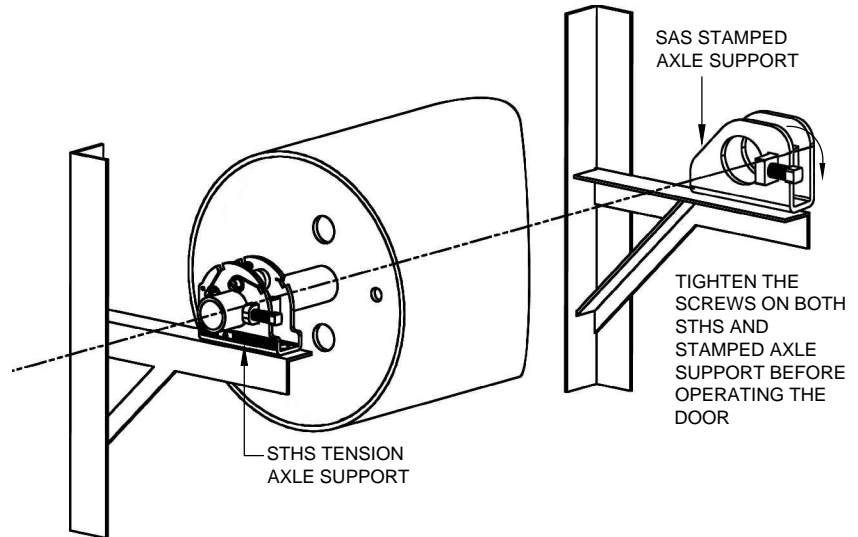

STEP #4 -ADJUST (RELEASE) THE TENSION ON THE SPRINGS.

IF THE TENSION OF THE DOOR NEEDS TO BE RELEASED, FOLLOW THE INSTRUCTIONS BELOW:

- UNTIGHTEN THE SET SCREWS ON THE STHS TENSION AXLE SUPPORT AND SAS STAMPED AXLE SUPPORT. APPLY MORE TENSION TO THE SHAFT WITH A PIPE WRENCH OR MECHANICAL DEVICE.
- WHILE HOLDING THE PIPE WRENCH, RELEASE THE STHS CAMS BY PUSHING UPWARD ON THE SPRING PIN.
- RELEASE THE SPRING TENSION BY KEEPING THE CAM DISENGAGED UNTIL YOU REACH THE CORRECT LOAD.
- PUT THE STHS CAM BACK IN PLACE TO HOLD THE SHAFT TORQUE AND RETIGHTEN THE SET SCREWS ON THE STHS AND STAMPED AXLE SUPPORT.

A) APPLY MORE TORQUE LOAD.

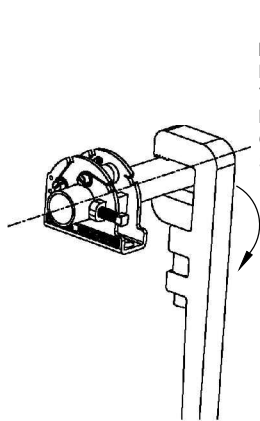

B) THEN RELEASE THE CAM BY PUSHING ON THE SPRING PIN.

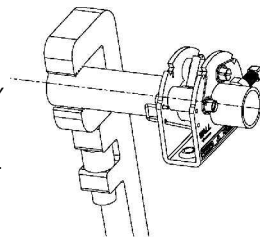

C) KEEP THE STHS CAM DISENGAGED BY PUSHING THE SPRING PIN. THEN RELEASE TENSION ON THE DOOR.

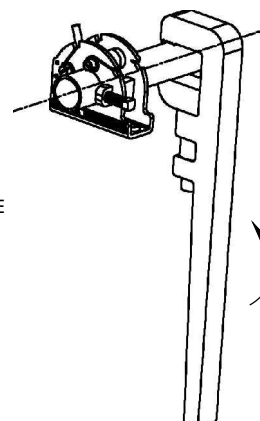

D) RELEASE THE SPRING PIN.

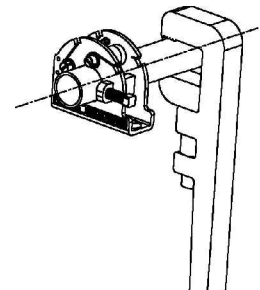

⚠ WARNING

WHEN ADJUSTING THE TENSION, THE TORQUE LOAD IS MAINTAINED BY THE FRICTION BETWEEN THE SHAFT AND THE CAM OF THE STHS. DO NOT MODIFY THE FRICTION COEFFICIENT BY OILING, PAINTING OR ALTERING THE SURFACE FINISH OF THE SHAFT.

STHS MUST BE USED WITH TUBULAR SHAFT MEETING ASTM A513.

FAILURE TO RESPECT THOSE INSTRUCTIONS COULD CAUSE THE SHAFT TO SLIP FROM THE STHS AND RESULT IN SERIOUS INJURIES.

NEVER OPERATE THE DOOR IF THE SET SCREWS ARE NOT FULLY TIGHTENED ON BOTH THE STHS TENSION AXLE SUPPORT AND THE SAS STAMPED AXLE SUPPORT. FAILURE TO DO SO COULD RESULT IN SERIOUS INJURIES.

SPRING ADJUSTMENT MUST BE DONE WHILE THE DOOR IS LOCKED IN ITS OPEN POSITION. FAILURE TO DO SO COULD RESULT IN SERIOUS INJURIES.

THE DOOR TENSION MUST BE FULLY TRANSFERRED TO THE PIPE WRENCH BEFORE RELEASING THE TENSION ON THE STHS. NEVER FORCE THE SPRING PIN. THE DOOR TENSION MUST BE RELEASED FROM THE STHS BEFORE PUSHING ON THE SPRING PIN. FAILURE TO DO SO COULD RESULT IN SERIOUS INJURIES.