



ASTAAMERICA

BY JANUS INTERNATIONAL

R O L L I N G S T E E L D O O R S

4255 McEver Industrial Drive

Acworth, Georgia 30101

Phone: (770) 974-2600 Toll Free: (800) 423-0659

Fax: (770) 974-1455

Installation Instructions

Models: FS522/M - FS522/C

FS566 - FS566M

Fire Counter

Shutter

Tension Side View

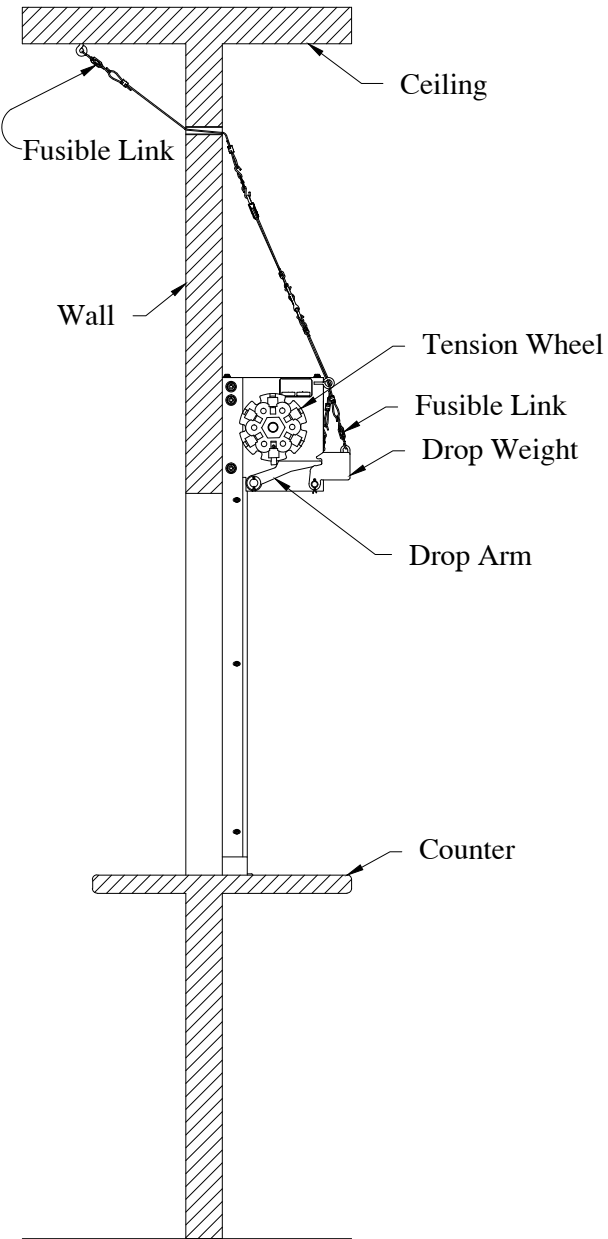

Front View

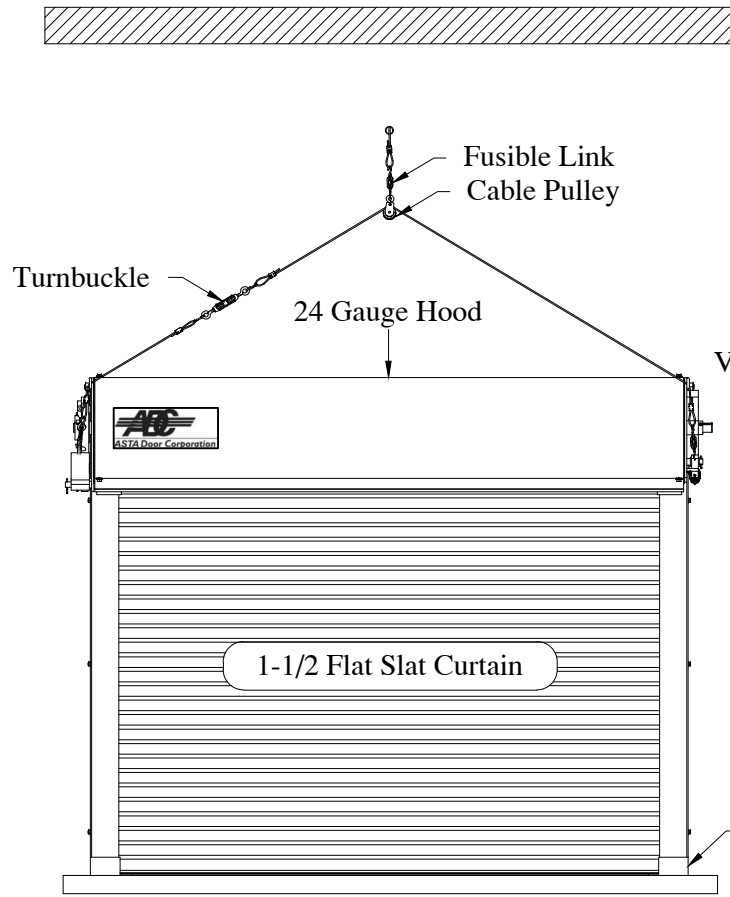

Drive Side View

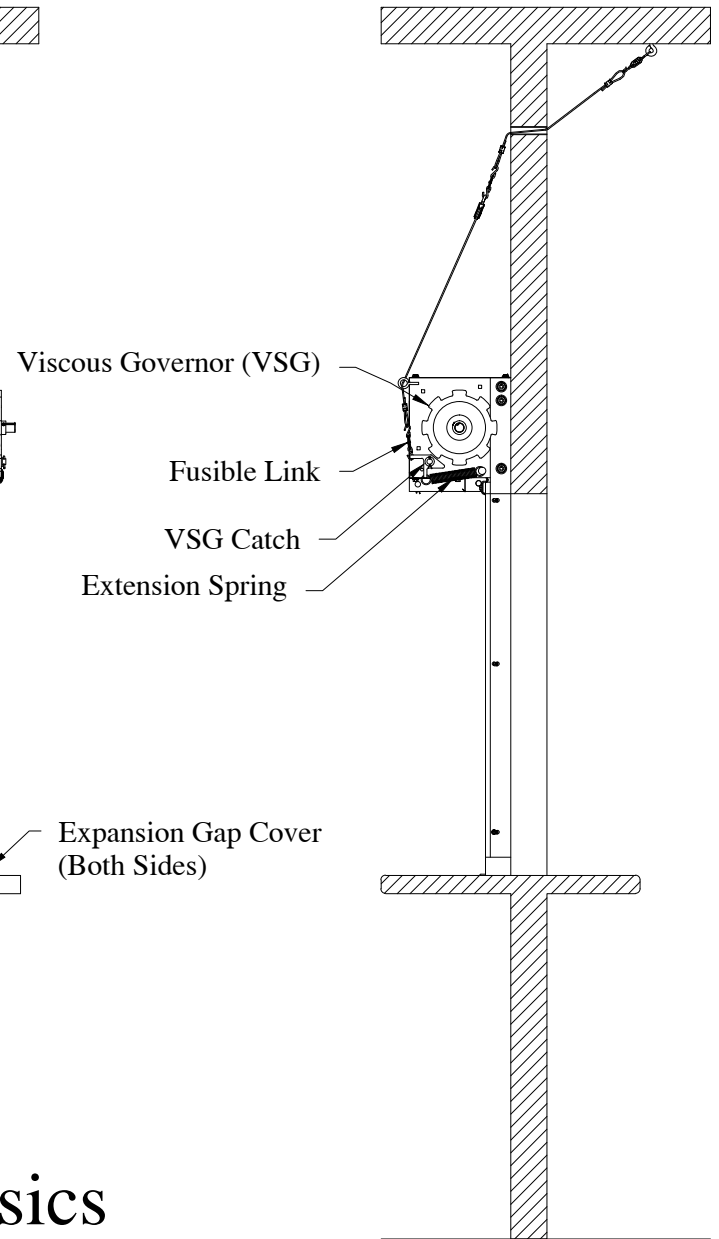

Fire Counter Shutter Basics



ASTA Door Corporation

Guide Basics

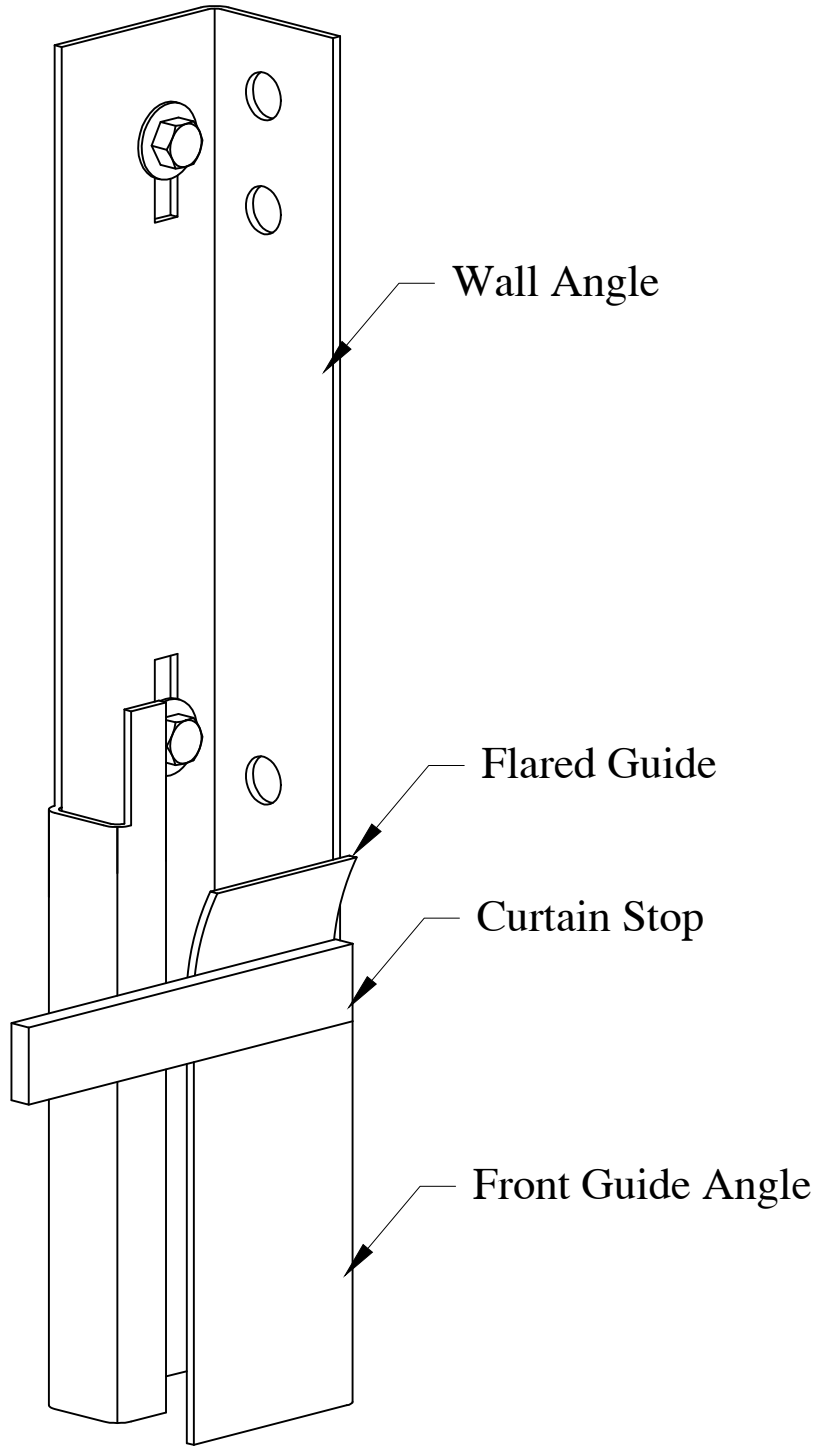

TABLE OF CONTENTS



Fire Counter Shutter Basics

Guide Basics

Sections:	1.0	General	Page	1
	2.0	Shipment Inspection	Page	1
	3.0	Checking Shutter Requirements	Page	1
	4.0	Existing Conditions	Page	1
	5.0	Preparation	Page	1
Section:	6.0	Guide Installation	Pages	2-5
Section:	7.0	Part Identification	Pages	6-9
Section:	8.0	Barrel Installation Procedure	Page	10
Section:	9.0	Curtain Installation	Page	11
Sections:	10.0	Guide Installation	Page	12
	11.0	Expansion Gap Cover	Page	12
Section:	12.0	Tensioning the Barrel	Pages	13-14
Section:	13.0	Hood Installation	Page	14
Sections:	14.0	Label Installation	Page	15
	15.0	Slide Lock Installation	Pages	15
Section:	16.0	Fusible Links	Pages	16-17
Section:	17.0	Tension Release Setup and Adjustment	Page	18-19
Section:	18.0	Drop Testing and Resetting	Page	19-20
Section:	19.0	Maintenance	Page	21
Section:	20.0	Painting	Page	22
		Trouble Shooting	Page	23

ASTA FIRE COUNTER SHUTTER INSTALLATION INSTRUCTIONS

These instructions will show you how to install a ASTA Fire Counter Shutter. They are for the mechanically experienced person who has proper tools to perform the job. They are not meant to infringe upon or supercede any State or County building codes, fire codes or safety regulations.





Safety first. Safety warnings are clearly marked with a  **WARNING!!** symbol. Critical information is identified by a  **CRITICAL!** symbol. Tips are marked with a  symbol. Observe all guidelines, warnings, tips and critical information given in the instructions during installation.

 **WARNING!! Wear protective gloves and eye wear when working on the door.**



1.0 GENERAL: Read and familiarize yourself with this entire manual before proceeding with installation. Contact ASTA for technical information at 4255 McEver Industrial Drive Acworth, Georgia 30101. Toll Free:(800) 423-0659

2.0 SHIPMENT INSPECTION: When the shipment arrives check for freight damage and missing items. Use packing list to determine completeness of shipment. If there is damage or if shortage is detected, contact ASTA immediately.

3.0 CHECK DOOR REQUIREMENTS: Use shop drawing to verify the following:

-  Width of opening
-  Height of opening
-  Headroom
-  Sideroom
-  Backroom at header

4.0 EXISTING CONDITIONS

-  Is counter level?
-  Is header level?
-  Are jambs plumb?

4.1 Inspect jambs and adjacent wall construction to verify that they are suitable for anchoring guide assemblies. ASTA is not responsible for the structural soundness of existing jambs and adjacent wall construction.

 **WARNING!! If in doubt of the fitness or structural integrity of jambs, a qualified engineer must inspect the existing conditions before proceeding further.**

 **WARNING!! Guides are not intended or designed to act as structural reinforcement for existing jambs. Jamb surface must extend full height of wall angle.**

 **WARNING!! Installation of anchoring devices into unsound building material will result in product damage, personal injury, premature wear and product failure.**

5.0 PREPARATION

5.1 Clean and sweep work area of any debris or objects that may interfere with installation or damage the curtain. Place guides and curtain on protective cardboard if possible.

5.2 Position all components on the floor in the approximate location they will be later assembled. Double check for completeness of shipment at this point.

6.0 GUIDE INSTALLATION: Fasteners for mounting guides are supplied by ASTA

STEEL JAMBS

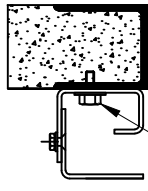
DETAIL VIEW	FASTENER SUPPLIED	DRILL SIZE	TAP SIZE
 <ul style="list-style-type: none"> ✓ Self Tap Screw ✓ 3/8" PVC Washer 	3/8" Hex Head Thread Cutting Screws	5/16" Drill	N/A
	2 - 1/2" Hex Head Thread Cutting Screws	29/64" Drill	N/A

CONCRETE/ FILLED BLOCK

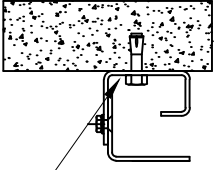
DETAIL VIEW	FASTENER SUPPLIED	DRILL SIZE	💡 NOTES
 <ul style="list-style-type: none"> ✓ Sleeve Type Expansion Anchor ✓ PVC Washer 	3/8" Sleeve Anchor	3/8" Drill	Do not drill holes closer than 4" to the edge of any masonry.
	2 - 1/2" Sleeve Anchor	1/2" Drill	

HOLLOW BLOCK/SOFT BRICK JAMBS

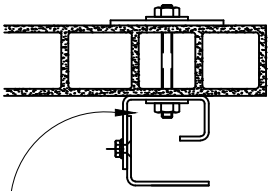
DETAIL VIEW	FASTENER SUPPLIED	DRILL SIZE	💡 NOTES
 <ul style="list-style-type: none"> ✓ 4 x4 Crush Plate ✓ Hex Nuts ✓ Thru Bolt ✓ PVC Washers 	3/8" Thru Bolts	3/8" Drill	-Do not drill holes closer than 4" to the edge of any masonry. -Required: 4" x 4" Crush Plates under nut on opposite side of wall.
	1/2" Thru Bolts	1/2" Drill	

SHEETROCK JAMBS

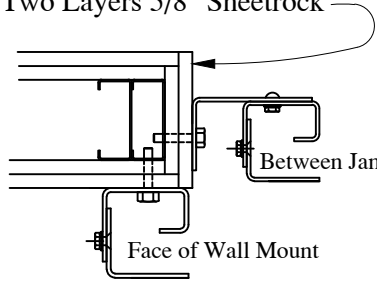
DETAIL VIEW	STEEL STUD	WOOD STUD
Minimum Two Layers 5/8" Sheetrock 	1-3/8"x 3-5/8" x 14 gauge minimum	2" x 4", 2" x 6", or 2" x 8"
	<ul style="list-style-type: none"> ✓ Drill 11/32" Pilot Hole ✓ 3/8" x 2" Type T Hex Head Tapping Screw 	<ul style="list-style-type: none"> ✓ Drill 1/4" Pilot Hole ✓ 3/8" x 2-1/2" Hex Head Lag Screw
	<ul style="list-style-type: none"> ✓ 3/8" x 2" Type T Hex Head Tapping Screw 	<ul style="list-style-type: none"> ✓ 3/8" x 2-1/2" Hex Head Lag Screw

READ AND BE SURE THAT YOU COMPLETELY UNDERSTAND ALL OF THE STEPS AND WARNINGS AS OUTLINED PRIOR TO BEGINNING INSTALLATION.

6.1 Guides are shipped assembled and consist of a wall angle (the longest angle) and a front angle. Between jamb mount guides are furnished with an extra angle (See Guide Basics).

💡 Accurate Guide Installation: Mark a level reference point on each jamb to insure guides are installed level with each other. Measure from the reference marks on each jamb to the counter to achieve identical elevations.

6.2 Face Mounted Standard Guides: Mark center of opening width on counter. Measure 1/2 "X" dimension (shown on shop drawing). This establishes the outside surface of the wall angle.

⚡ CRITICAL! The "X" Dimension is essential for proper curtain operation and must be held constant from top to bottom.

6.3 Disassemble guides.

Side Room Requirements: Face of Wall & Between Jamb Mount

<u>Operation Type</u>	<u>Tension Side Clearances</u>	<u>Drive Side Clearances</u>
Manual	6-1/2"	5-1/2"
Awning Crank	6-1/2"	7-1/2"

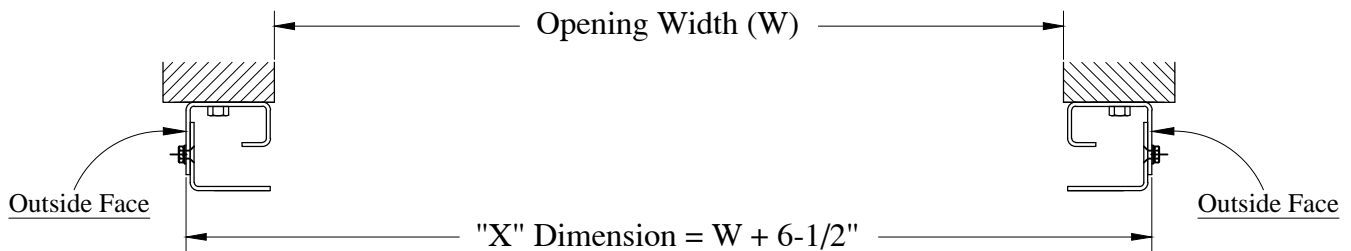

Standard Guide "X" Dimension

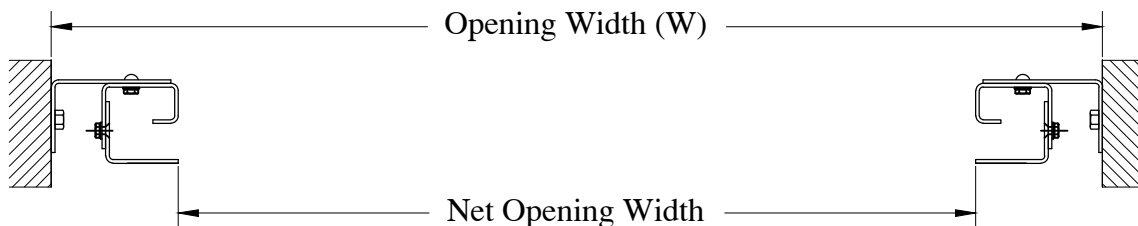

Net opening width = Opening Width - Tension side clearance - Drive side clearance

Between Jamb Guide Net Opening Width

⚡ **CRITICAL!** Check counter surface for slope. If counter is not level, place temporary shims under wall angles to achieve identical elevation for both sets of guides.

⚡ **CRITICAL!** Guides assemblies are required to have 3/4" expansion gap at counter.

💡 Create 3/4" expansion gap by setting wall angle on a short 1 x 4 block, then shimming as necessary to achieve identical elevation between both sets of guides.

💡 After wall angle is positioned, clamp to jambs to maintain a fixed position while setting fasteners.

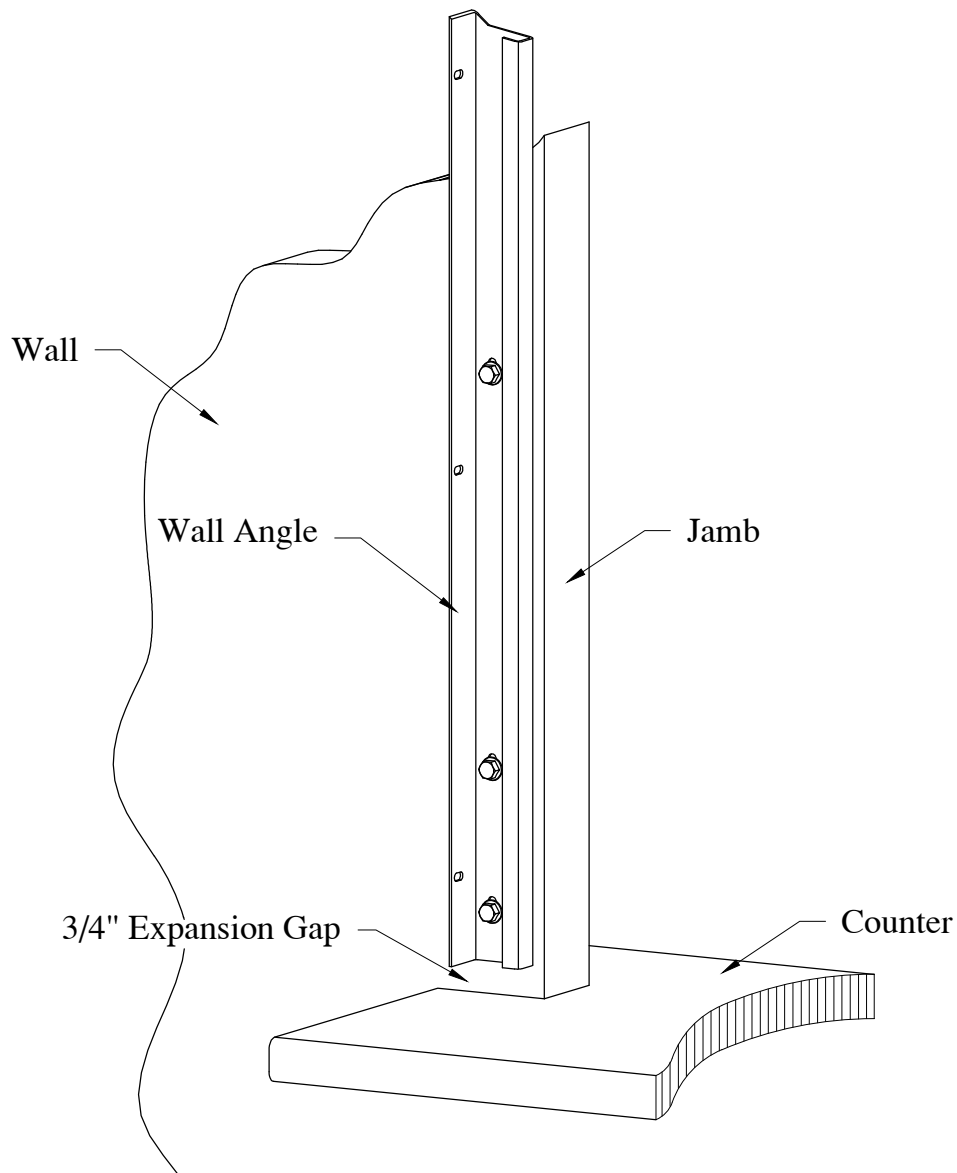

⚡ **CRITICAL!** Fastener Location: This step is required by design and for Fire Shutter Label compliance. It must be strictly followed for proper expansion of fire shutter guides when exposed to heat and/or flame. The fastener at the top of each wall angle must be in the top of the top slot. All remaining fasteners must be in the bottom of each slot.

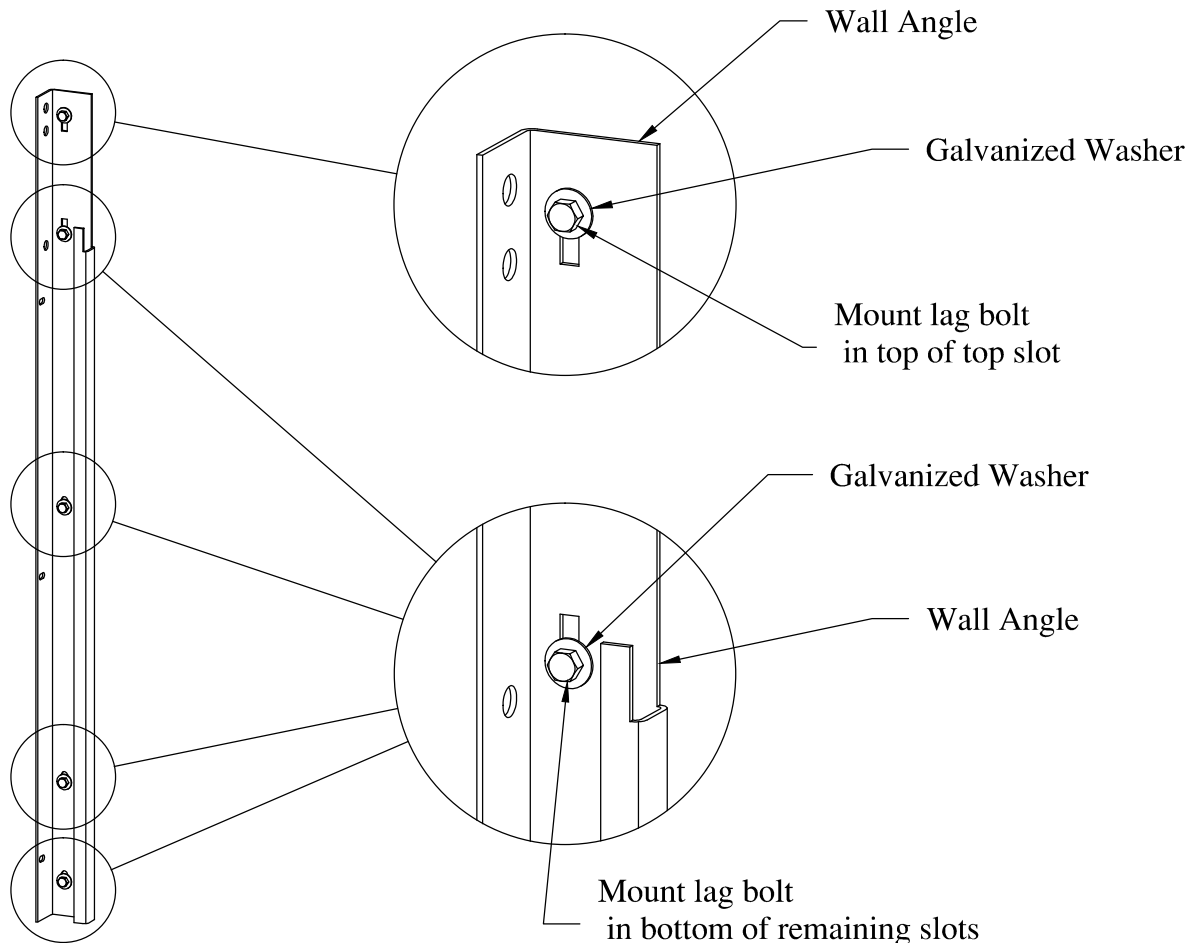

Fire Shutter Fastener Location

- 6.4 Once appropriate fasteners and locations have been determined, drill holes and attach wall angle. Do not tighten fasteners until wall angle is plumb and at the desired elevation.
- 6.5 Mount opposite wall angle, paying close attention to the "X" dimension. This guide may be set by using a tape measure, provided the first guide is set correctly. Use several reference points to determine an accurate "X" dimension top to bottom.

⚡ **CRITICAL!** Review all fastener locations, elevations of guides and "X" dimension before proceeding. ASTA will not warranty any shutter that does not have guides set plumb and level with each other, with incorrect spacing between guide faces or with fasteners set in improper locations as per installation instructions.

7.0 PART IDENTIFICATION

7.1 Identify drive side and tension side head plate. Drive side head plate must match drive side shown in shop drawing (LH Shutter- Drive & Tension Headplates opposite as below).

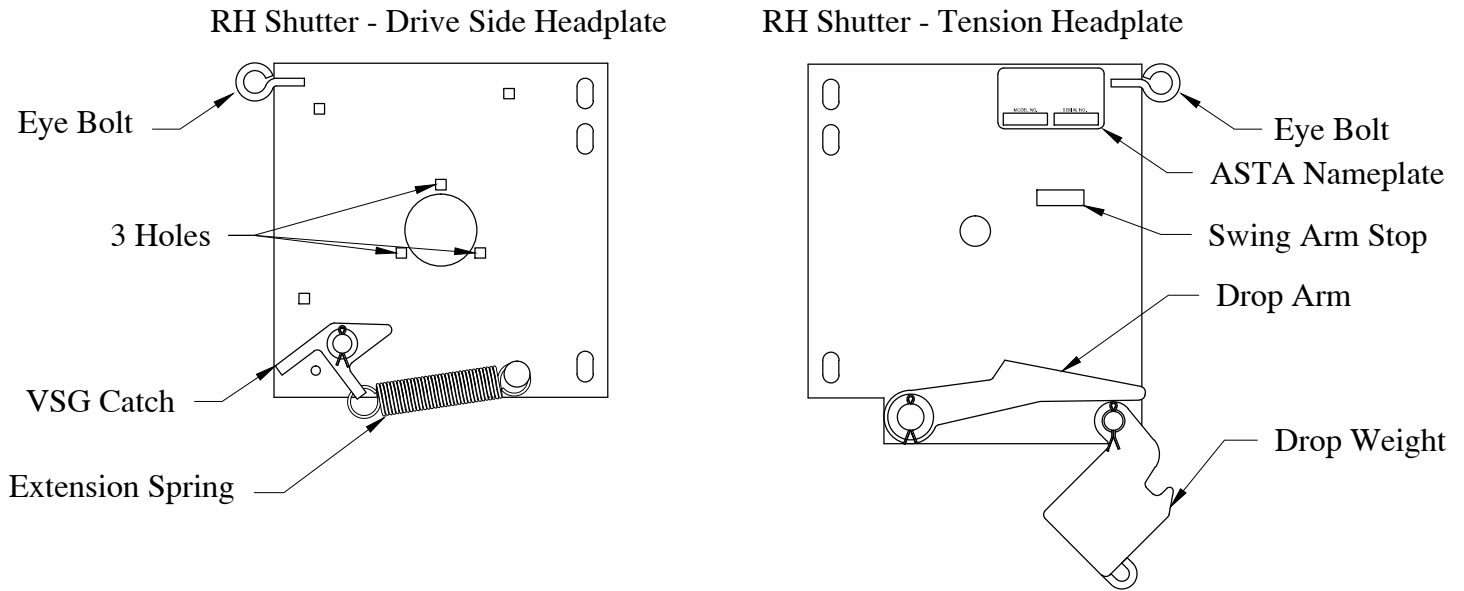

RH Shutter: Manual and Awning Crank Headplates

7.2 Barrel ends are identified by drive side and tension side.

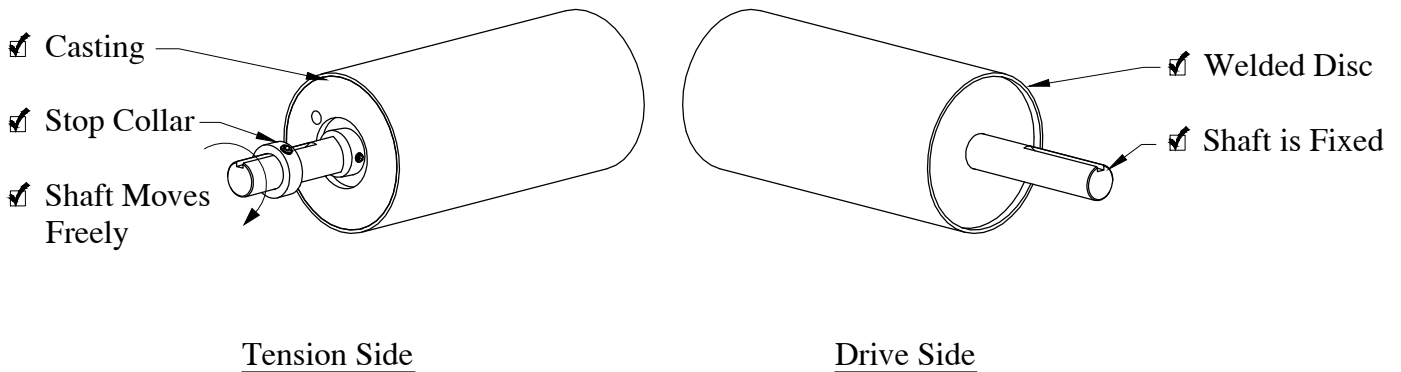

7.3 Tension Side Assembly.

 **This process is easier if you elevate the barrel to waist height.**

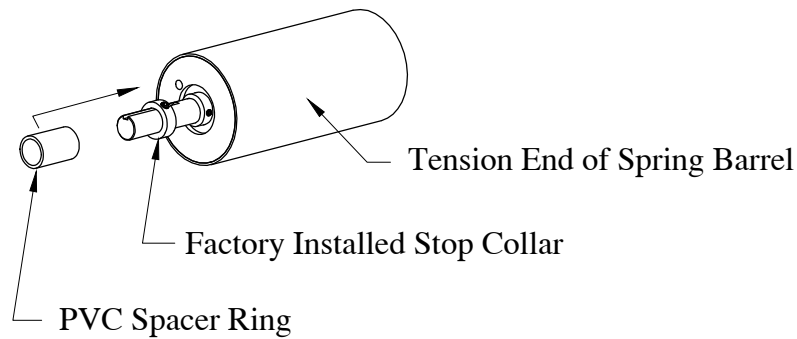

- ✓ Loosen stop collar
- ✓ Identify PVC spacer ring and slide onto end of shaft to stop collar.

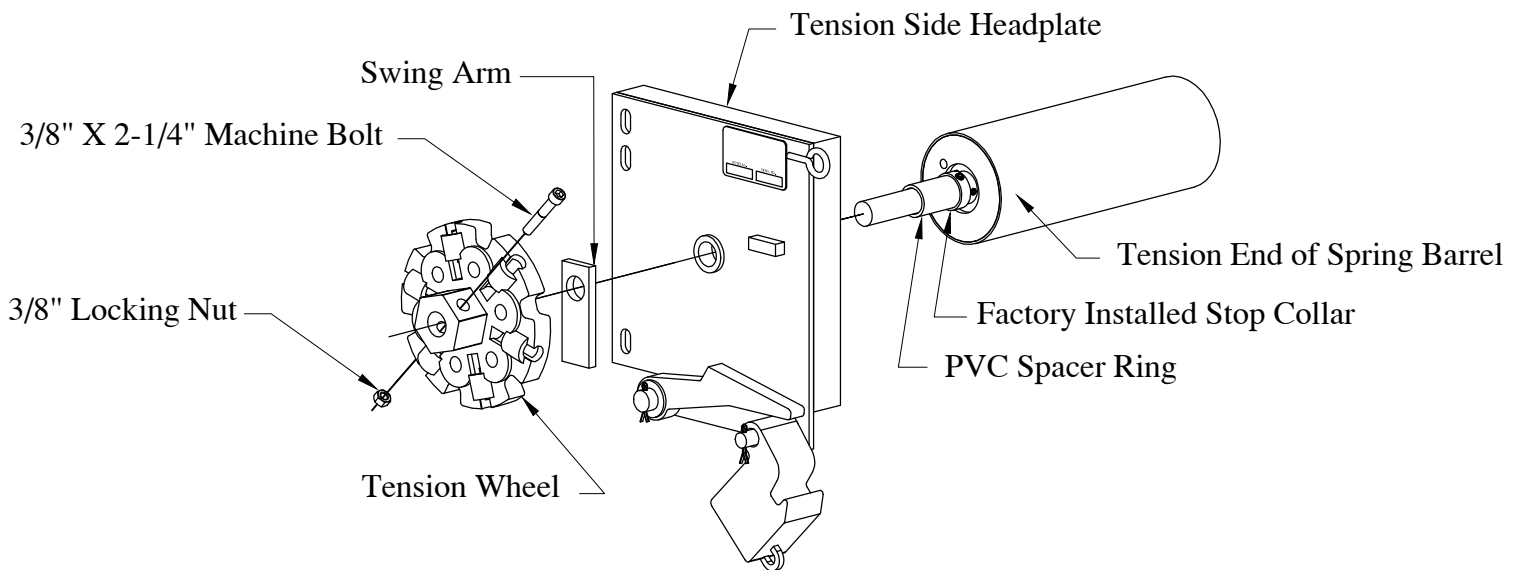

- ✓ Slide tension side headplate onto shaft.
- ✓ Slide swing arm onto tension shaft.
- ✓ Slide tension wheel onto shaft until hole in tension wheel aligns with hole in tension shaft.
- ✓ Insert 3/8" machine bolt through tension wheel and tension shaft and tighten locking the tension wheel in place.
- ✓ Slide headplate outward against tension wheel.

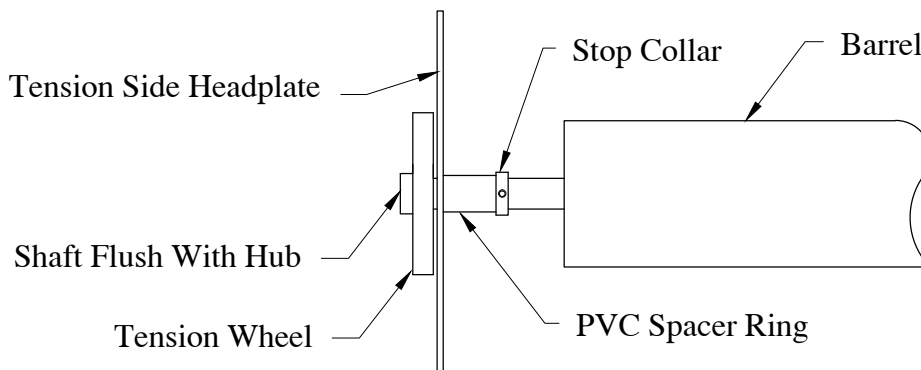

- ✓ Slide PVC spacer out to headplate.
- ✓ Slide stop collar to PVC spacer ring and tighten set screws in stop collar.

- 7.4 **Manual Drive End Assembly: Manually Operated Curtain:** Locate bearing assembly and bolt to inside face of drive side headplate with three 5/16" x 1" carriage bolts and nuts. Slide the drive side headplate onto drive shaft.

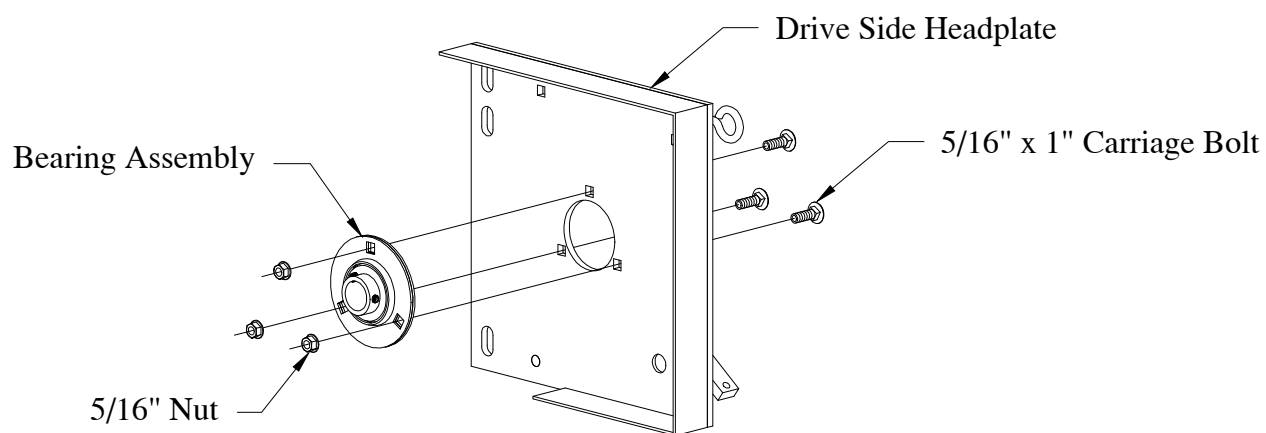

Manual Drive End Assembly

- 7.5 **Governor Assembly: Manually Operated Curtain:** Slide two bronze thrust washers onto the drive side shaft. Slide on viscous speed governor (VSG) aligning keyway in VSG with keyway on shaft and insert key stock. Slide stop collar onto shaft and secure assembly in place by tightening set screw in stop collar.

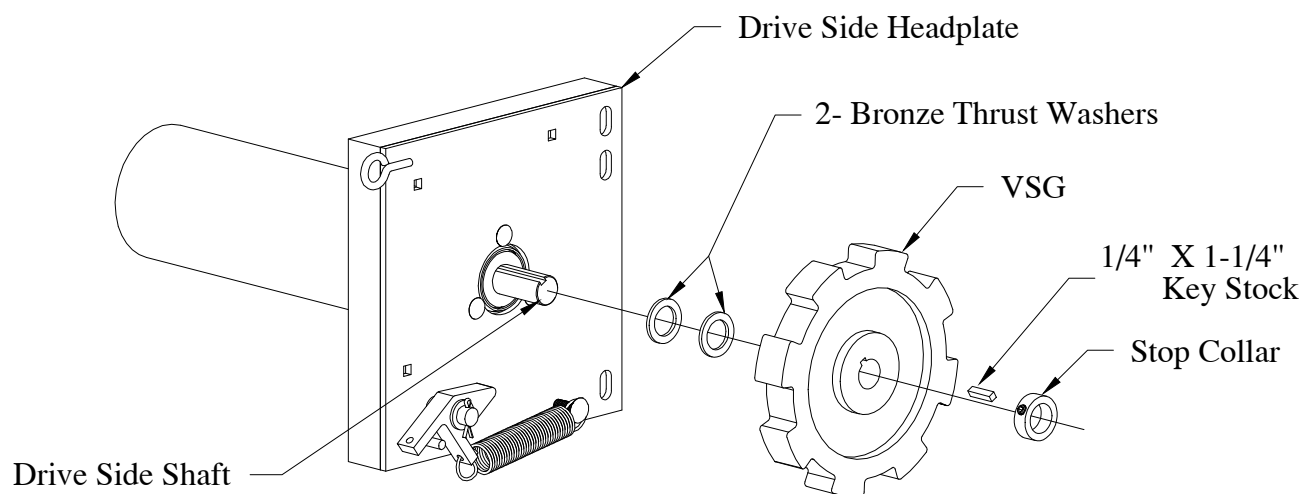

Governor Assembly: Manually Operated Shutter

7.6 **Governor Assembly: Awning Crank Operated Curtain:** Slide one 1" I.D. x 2-1/2" O.D. galvanized washer onto drive side shaft. Slide on viscous speed governor (VSG) aligning keyway in VSG with keyway on shaft and insert one key stock. Slide bronze thrust washer onto shaft. Slide awning crank mounting plate onto shaft and secure using three 5/16" x 2-1/2" carriage bolts, spacers and 5/16" nuts. Slide second 1" I.D. x 2-1/2" O.D. galvanized washer onto shaft followed by crank gear. Lubricate crank gear with grease before installing crank housing. Align keyway in gear hub with keyway in shaft and insert second key stock. Slide crank housing onto axle and fasten using three 1/4" x 3/4" flange bolts.

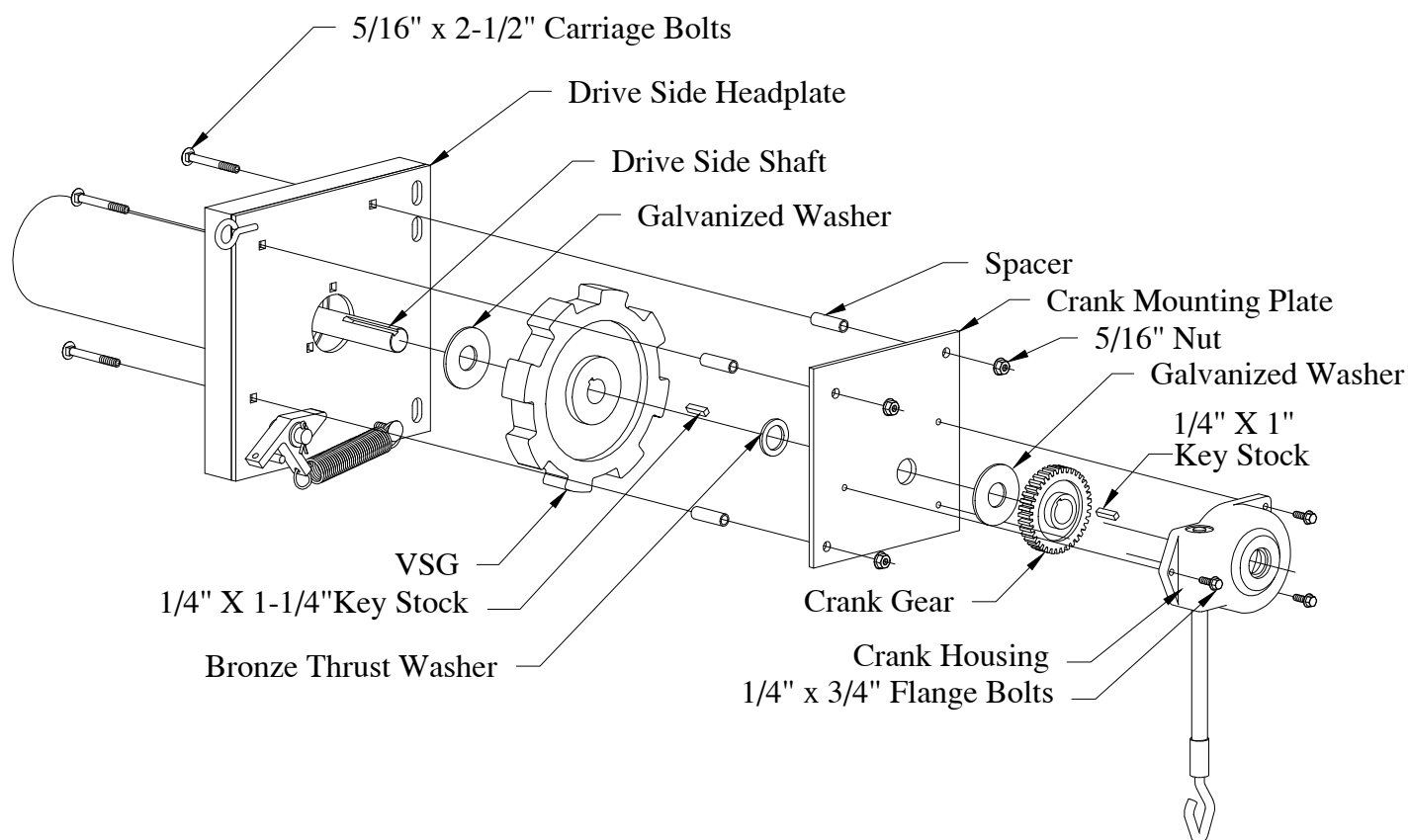

Governor Assembly: Awning Crank Operated Curtain

8.0 BARREL ASSEMBLY INSTALLATION

- ⚠ **WARNING!!** Secure all loads to hoist equipment to prevent movement while hoisting. Do not allow personnel to ride hoist equipment. Stay off ladders and lifts until barrel and/or curtain have been hoisted to the final position of attachment. Serious personal injury will result from carelessness or lack of planning. Plan all moves carefully!
- ⚠ **WARNING!!** It is essential that you use hoisting equipment of adequate stability and rated capacity to safely lift the barrel and head plate assemblies.

8.1 Carefully raise the barrel assembly into position to bolt headplates to wall angles. Head plates mount to the inside face of wall angles with three 1/2" x 1" carriage bolts. Bolts are inserted from inside of headplate facing out.

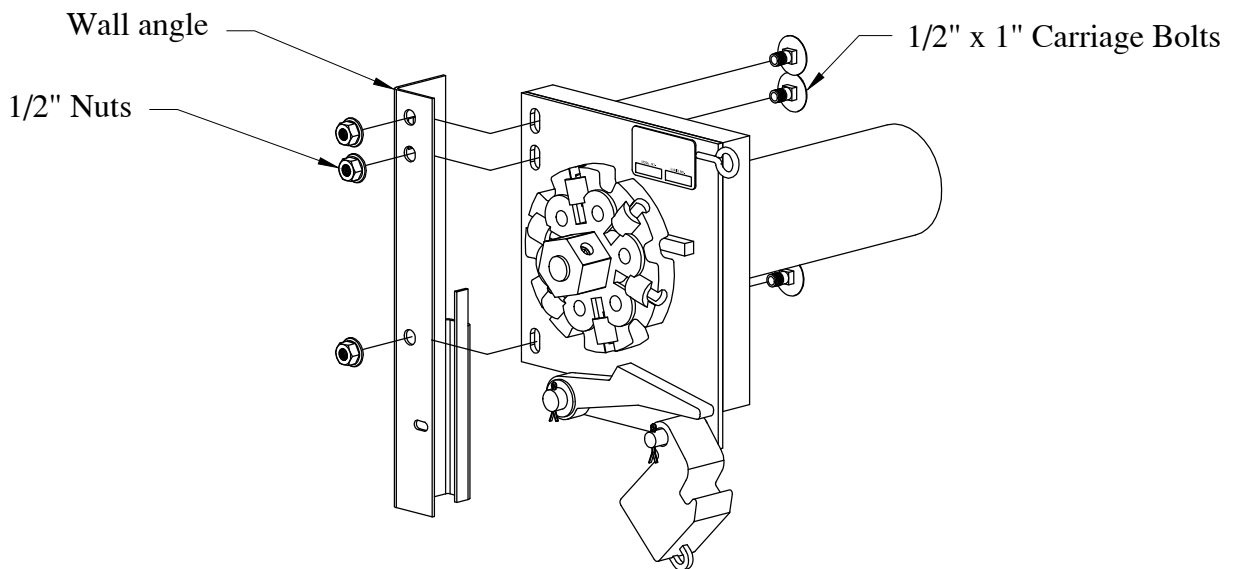

Tension Side Headplate Mount

⚡ **CRITICAL!** Do not proceed until barrel is level.

8.2 Once barrel is level, tighten all fasteners securely.

8.3 Check barrel rotation. Barrel should turn freely without binding.

💡 **At this time double check hood length. Hood length measurement should be approximately 1/2" shorter than the distance between headplates to allow for proper expansion.**

💡 **Measure distance between drive side and tension side headplates at wall and at the front of the headplates. Square headplates by checking width front and rear.**

8.4 Set drive side bearing set screws at this time to fix headplate.

9.0 CURTAIN INSTALLATION

 **REMINDER:** Before installing curtain, note number of preload turns written on barrel and record that number in the space provided on page 13 section 12.2. After curtain installation barrel will be covered by curtain and preload turn number written on barrel will no longer be visible.

- 9.1 Secure curtain to hoist and lift into place directly under barrel assembly.
- 9.2 Use a minimum of two straight eye nylon slings, with a minimum working rating of 2,500 pounds per sling, to encircle barrel and curtain. Fasten ends of slings together with screw pin clevises or chain shackles with a minimum working rating of 2,500 pounds per shackle.
- 9.3 Lower curtain to rest in slings.

 **NOTE:** Hoisting equipment may be used at this point to lift curtain slightly, allowing barrel to be rotated manually or by awning crank to help alignment of fastening points.

- 9.4 Attach curtain segments to welded nuts on barrel with 5/16" x 3/8" button head screws. Center curtain between headplates and tighten button head screws.

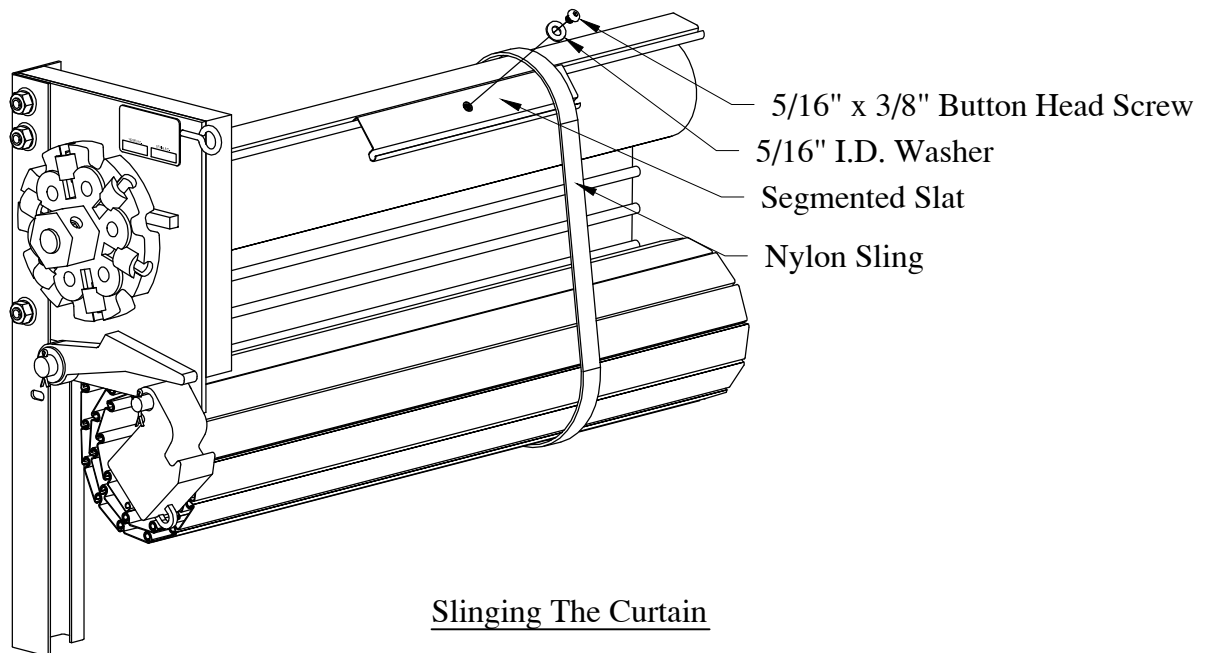

- 9.5 Transfer curtain from sling to barrel by slowly adding tension to the tension wheel and carefully rolling the curtain and barrel by pulling down on the slings, (see 12.0), until the curtain is transferred to the barrel completely. Nudge curtain slats left or right to maintain center between headplates. Be careful not to over tension barrel. Tie curtain with a temporary rope, to keep from unwinding.
- 9.6 Unwind tension wheel to relaxed position.

 **WARNING!!** Leave slings in place for now as a safety precaution.

10.0 GUIDE ASSEMBLY

- 10.1 Loosen temporary rope. Lower curtain until bottom bar is 3" below header. Retie the rope.
- 10.2 Raise front guide angle into position for attachment and align for bolting. Assemble using 1/4" x 1/2" x 82° countersink screws with nut. Install screws from inside front guide, fastening nut on outside of wall angle. Adjust front guide to produce a minimum gap for curtain travel.

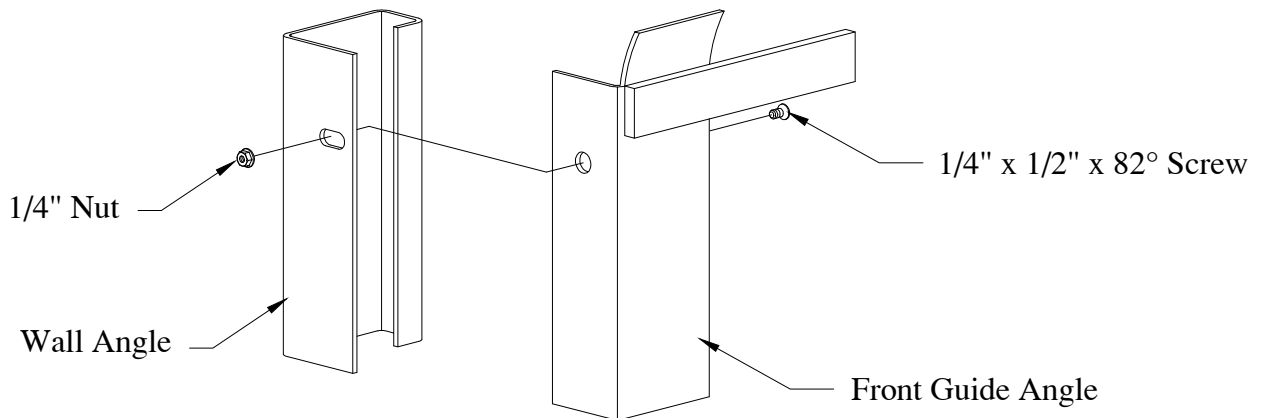

Guide Installation

11.0 EXPANSION GAP COVER

- 11.1 Install expansion gap cover at bottom of each guide using double sided tape attached to inside of cover.

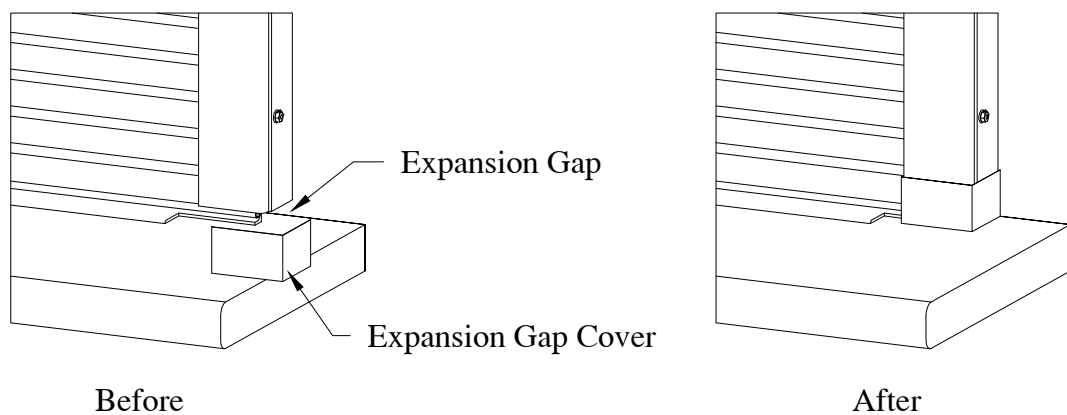

12.0 TENSIONING THE BARREL

- 12.1 Lift the drop arm and drop weight assembly as high as possible. Tie the drop weight securely to eye bolt at top of headplate.
- 12.2 Mark starting location of the tensioning wheel on head plate with chalk or marker for use as a reference while winding. At this time, refer to the specified preload number recorded below. Insert one winding bar into an uppermost lug in tensioning wheel **and pull down evenly**. Insert second bar into uppermost lug, remove first and pull second bar down evenly.

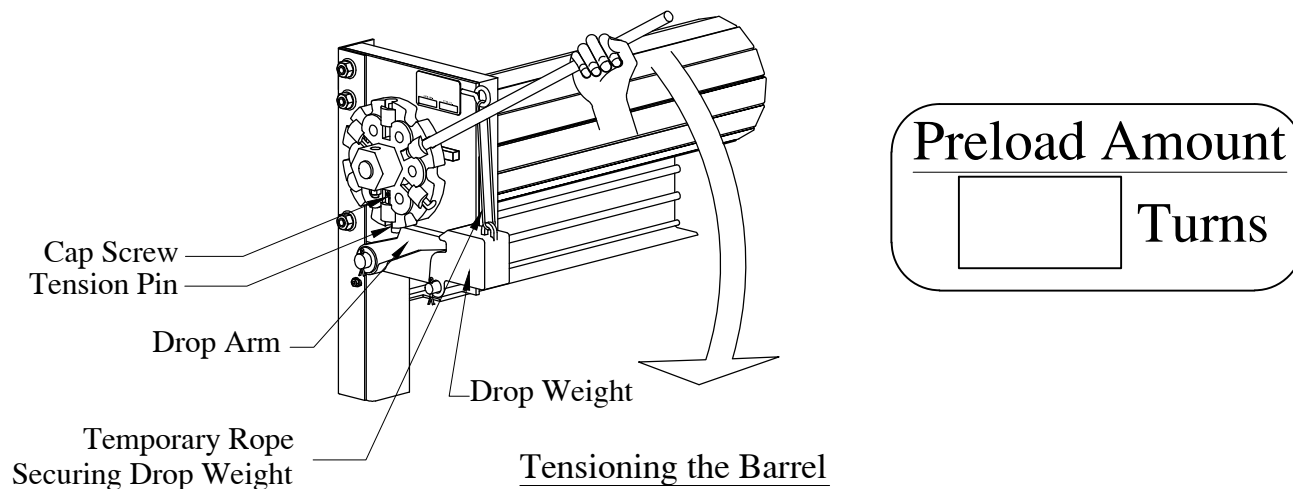

- ✓ **WARNING!!** Never exceed number of preload turns shown by more than one-half turn.
- ✓ **WARNING!!** Use solid steel winding bars. Be certain that winding bar diameter matches lug hole size on the tension wheel and is a minimum of 18" long. Be sure that the bar is inserted fully into the winding lug. Use of improper or undersized bars will result in component failure and cause serious personal injury or death.
- ✓ **WARNING!!** Keep your head and body out of line with the winding bars. Always maintain secure footing and balance. Firmly grasp the winding bars and be braced to resist strong forces whenever winding springs.
- ✓ **WARNING!!** From this point onward, the spring is under tension and extremely dangerous.

12.3 When appropriate preload is established, lock tension wheel against wall or ceiling with a winding bar. Insert tension pin into selected tension casting lug and secure it in place with 1/4"-20 X 1/2" socket head cap screw. Now, with winding bars, rotate tension wheel back until tension pin rest securely against drop arm.

12.4 Curtain should rise so that bottom bar rests against stops. It is now safe to remove slings.

12.5 Test curtain for full range of operation.

13.0 HOOD INSTALLATION

- 13.1 Position formed edge of hood retainer 1-3/4" down from top edge of headplates. Center retainer between headplates. Attach retainer to header with steel washers and fasteners suitable for construction. Place fastener in center of center slot and remaining fasteners to outside edge of slots (towards the jambs).
- 13.2 Center hood between headplates and fasten using 1/4" x 3/4" hex head self drilling screws. Mount all fasteners near outside edge of slot with PVC washers to allow for proper expansion.

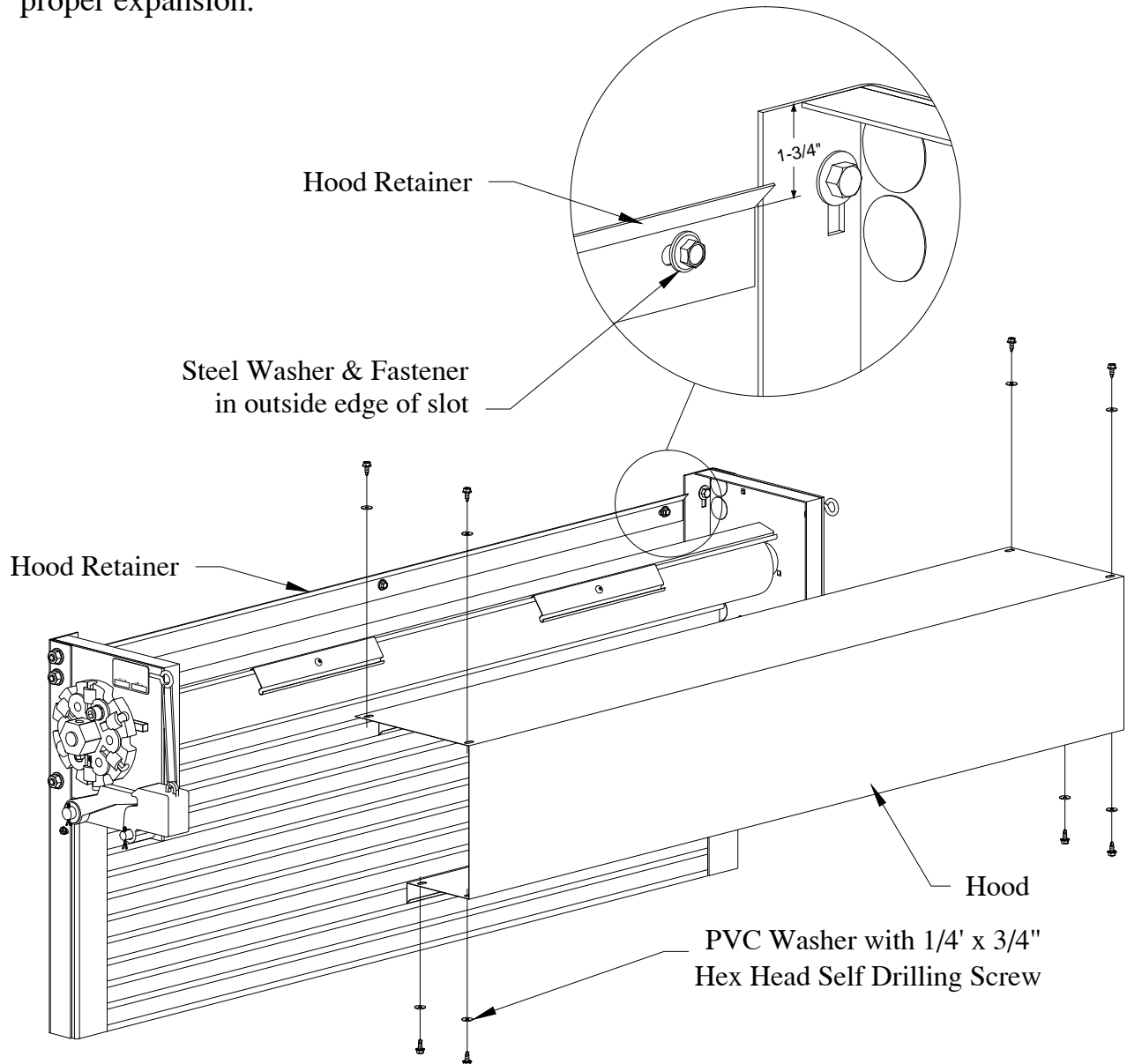

14.0 LABEL INSTALLATION

14.1 Place all "Warning" and "Caution" labels as instructed on labels. Be sure they are visible at all times.

15.0 SLIDE LOCK INSTALLATION

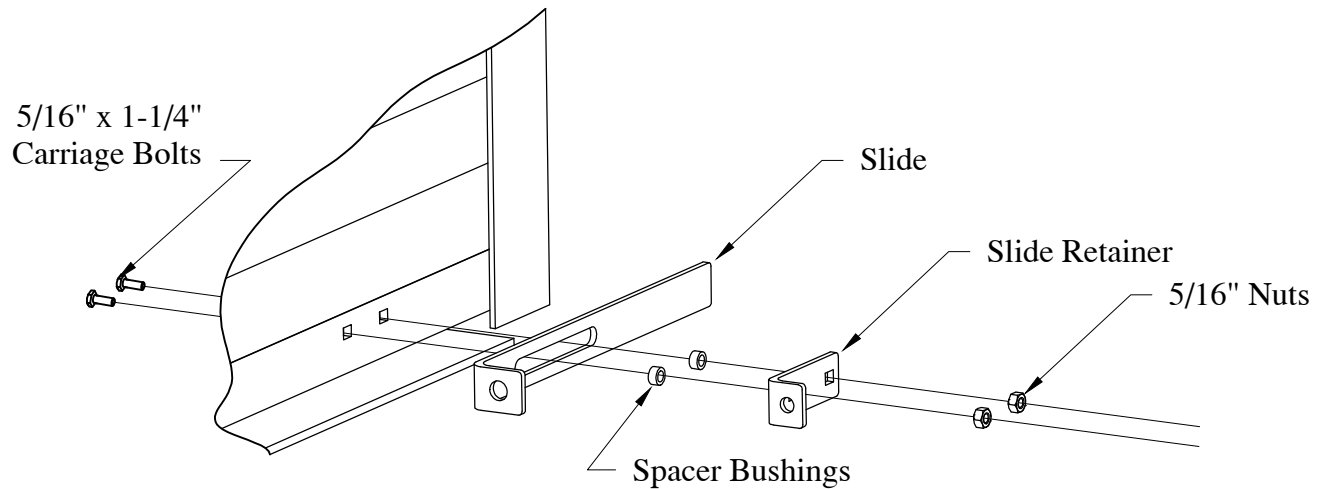

Slide Lock Installation

- 15.1 Move curtain so that bottom bar is at a comfortable working height and lock it in place.
- 15.2 Insert two 5/16" x 1-1/4" bolts from the outside through pre-punched holes in bottom bar.
- 15.3 Place the longer "L" shaped slide over carriage bolts flat against bottom bar with formed end towards the center of the curtain.
- 15.4 Place two spacer bushings in the slot and over carriage bolts.
- 15.5 With formed end facing towards center of curtain, place slide retainer over carriage bolts and thread. Tighten snugly, but do not over-tighten. Check slide action to make sure slide moves freely and engages slide lock keeper in bottom of front guide angle.

16.0 FUSIBLE LINKS: One fusible link is to be installed at each headplate.

⚠ **WARNING!!** Leave temporary rope securing drop weight in place until completion of the release cable assembly. Rope not shown in illustration for clarity.

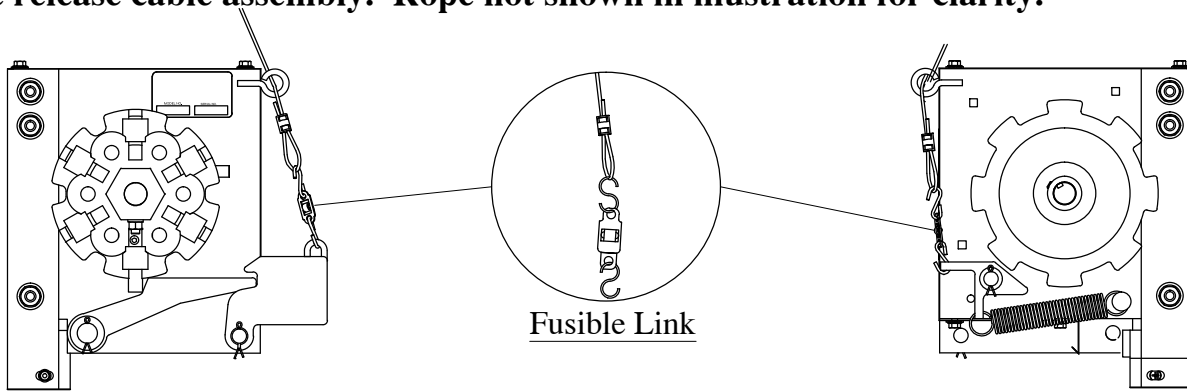

Tension Side Headplate

Drive Side Headplate

16.1 One fusible link is required within 12" of the ceiling intersection on the coil side. Another fusible link is required through the wall to within 12" of the ceiling intersection opposite the coil side. S-hooks are provided to connect fusible links to loops formed in cable with ferrules.

⚡ **CRITICAL!** Route cable and fusible links in such a way that the separation of any fusible link will release the cable causing counter balance assembly to instantly release tension and self close.

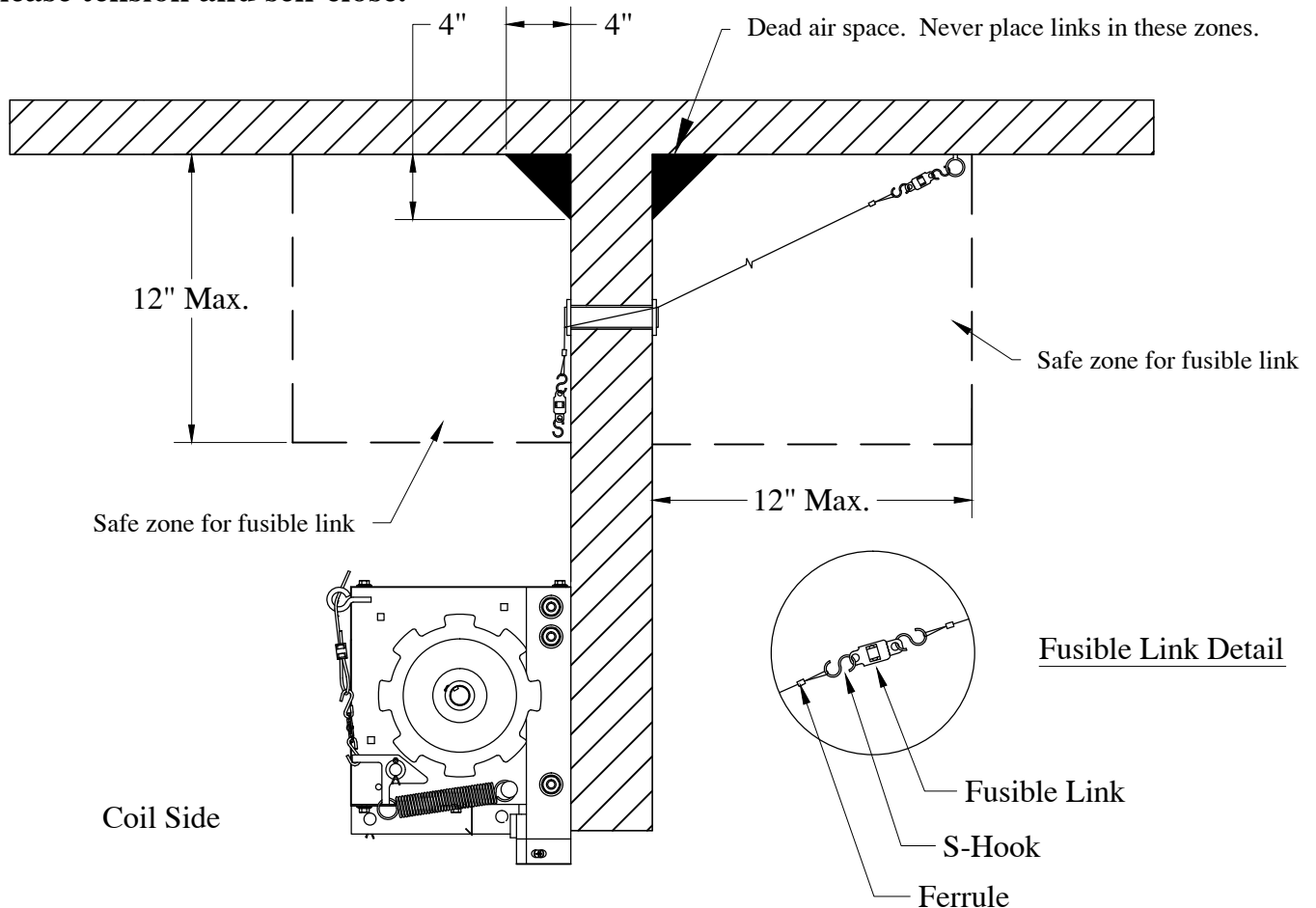

16.2 Cable assembly on coil side should be routed in manner shown below.

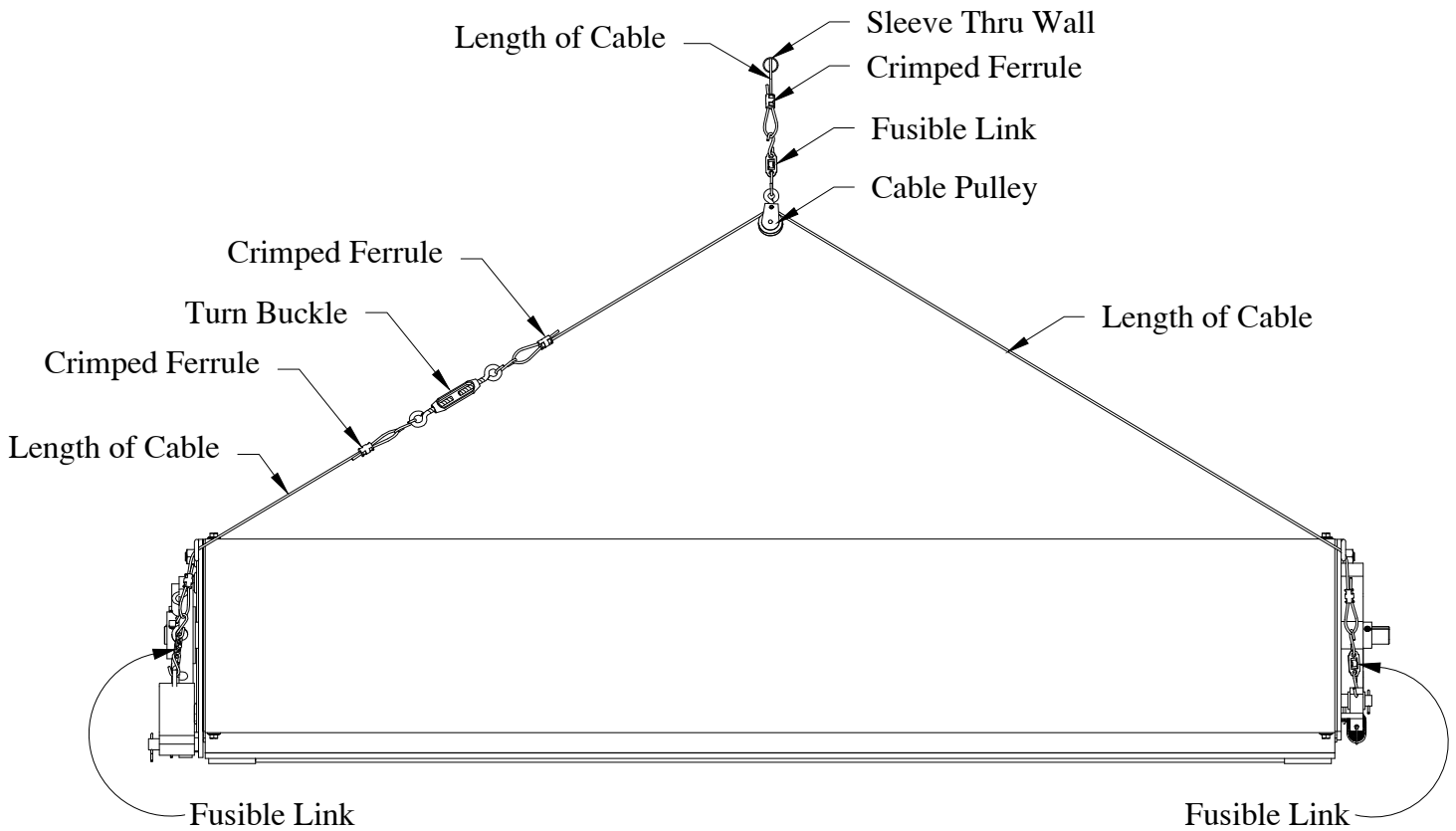

16.3 Cable assembly opposite coil side should be installed as shown below.

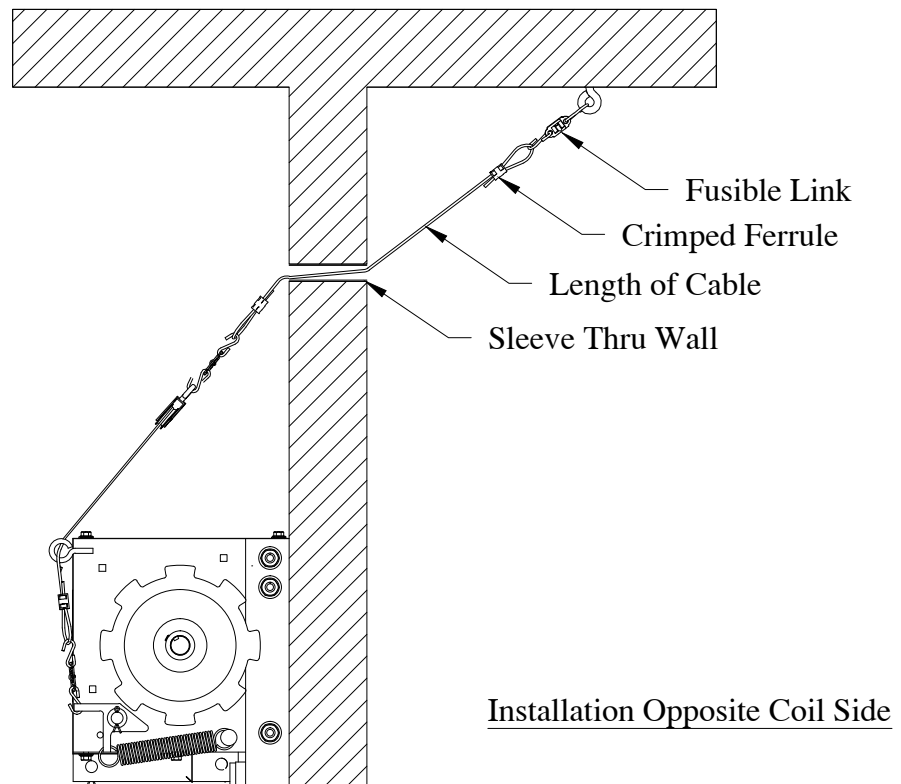

16.4 Tighten turnbuckle to remove slack in cable assembly. At this time it is now safe to remove temporary rope securing drop weight. Do not over-tighten.

17.0 TENSION RELEASE SETUP AND ADJUSTMENT

17.1 There are two starting positions for the swing stop, A and B based upon opening size.

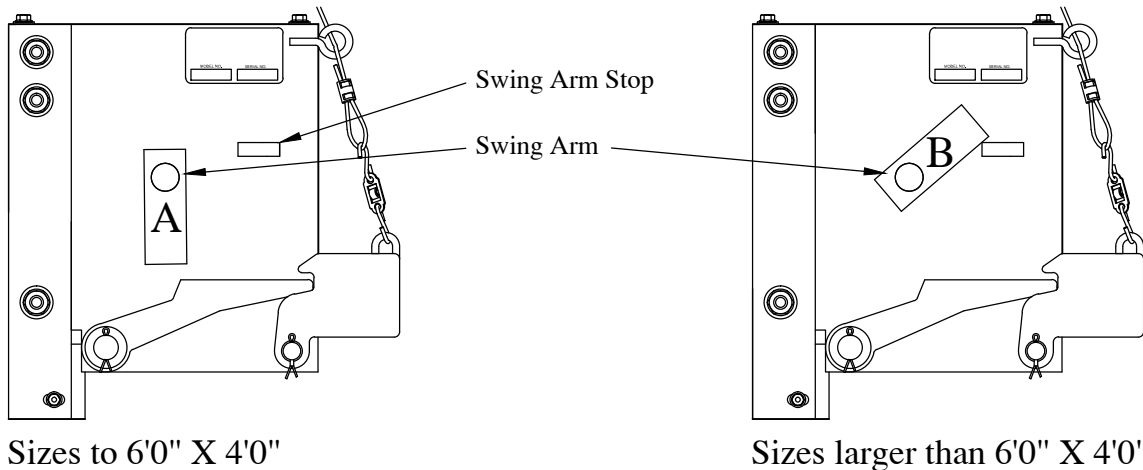

17.2 **If you place the swing arm stop in Position A**, thread the large socket head stop bolt and lock washer into the tension wheel at the 11:00 to 1:00 positions and tighten. This will release less than one turn of preload tension to put the curtain out of balance at the head. For less tension release and to minimize curtain drop speed, move the stop bolt to a more counter-clockwise position until it contacts the swing arm. To increase curtain speed, move the stop bolt to a more clockwise position. The curtain must drop reliably out of the head and close fully when tension is released. If there is not enough bolt adjustment for this to occur, place the swing arm into Position B and proceed as instructed in 17.3.

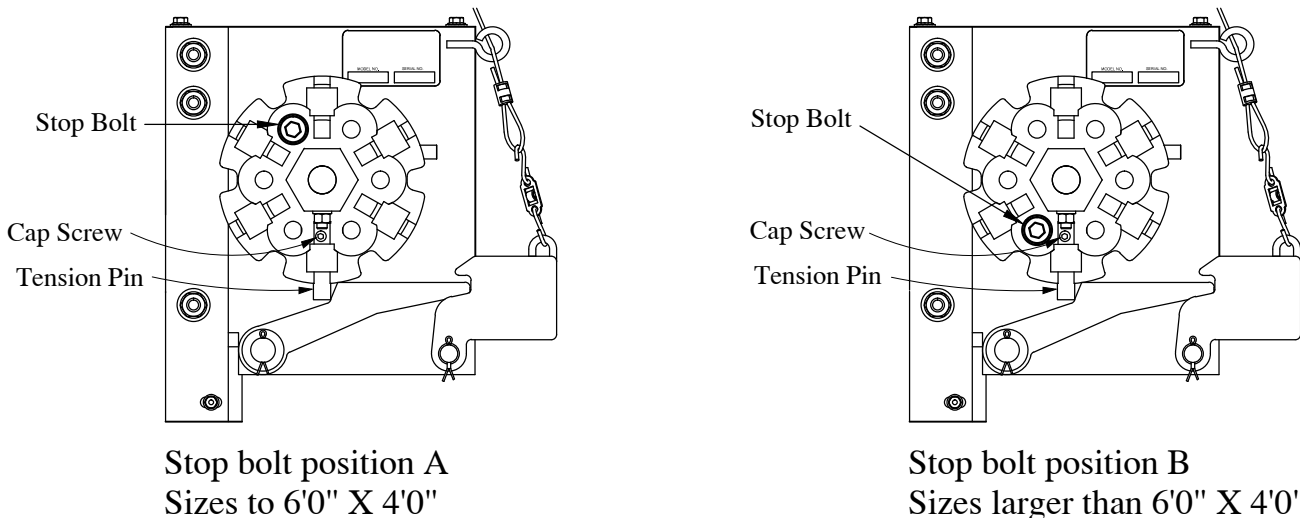

17.3 **If you place swing arm in Position B**, thread the large socket head stop bolt and lock washer into the tension wheel at the 3:00 to 7:00 positions and tighten. This will release more than one turn of preload tension to put the curtain out of balance at the head. For less tension release and to minimize curtain drop speed, move the stop bolt to a more counter-clockwise position. To increase curtain speed, move the stop bolt to a more clockwise position until it contacts the swing arm. The curtain must drop reliably out of the head and close fully when tension is released.

💡 Once appropriate curtain balance is achieved and the tension pin inserted, you may rotate the tension wheel backwards with the winding bars until you know approximately where a reliable out-of-balance point is reached at the head. This will help establish where to initially locate the swing stop and swing stop bolt positions.

✔ **Warning!! Before drop testing procedure be certain opening is in sight and clear of people and obstructions.**

✔ **Warning!! Spring tension is extremely dangerous. Adjustments should only be made by a qualified door technician.**

18.0 DROP TESTING AND RESETTING

18.1 Raise curtain to the full open position. Check opening for obstructions.

✔ **Warning!! Do not release cable from the tension wheel side!**

18.2 Relax the release cable slightly from a position not in the proximity of the tension wheel. Fully and quickly release the cable by opening an s-hook or by heating a fusible link. Partial tension must release instantly and curtain should start downward from the head. Closing speed may range from 6" to 24" per second, per NFPA-80.

💡 **If closing speed needs to be adjusted, refer back to 17.0 through 17.3.**

18.3 **Reset the tension assembly:** With winding bars, re-apply the amount of tension that was released by winding tension wheel back beyond its starting position and again lock temporarily with the winding bars. Lift drop weight and drop arm back into place and secure with temporary rope or with release cable. Reset release cable as explained in 16.0 - 16.4. Now rotate tension wheel with winding bars to cause tension pin to rest against drop arm as explained previously in 12.0 - 12.3.

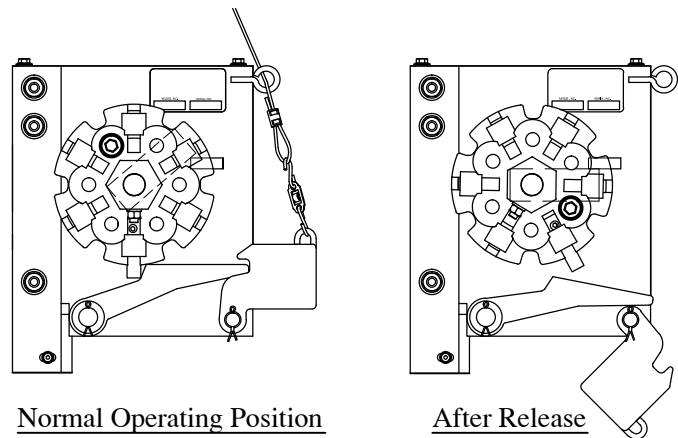

Drop Testing: Tension Side Views

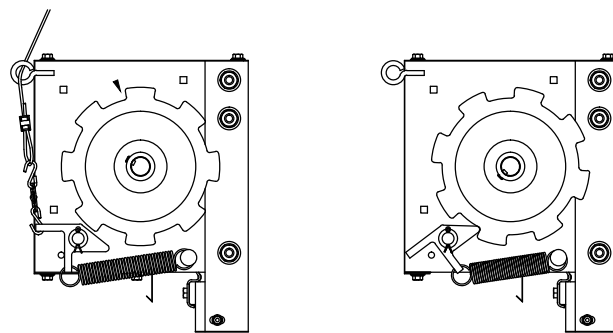

Drop Testing: VSG Side Views

- 18.4** Check curtain for correct balance at the open and closed positions.
- 18.5 Demonstrate a drop test and fill out the drop test form completely.** You must obtain the witness and signature of a suitable representative for a successful drop test demonstration to complete the installation. This may be the owner, or his assigned representative, such as the general contractor or maintenance person. It may be the local fire marshal. Refer to NFPA-80 to define the authority having jurisdiction, and familiarize yourself with the local code. The authority having jurisdiction can indicate who a suitable witness should be, and makes all final decisions regarding the installation of fire doors and shutters.
- 18.6 Give a copy of the installation and operational manual** to the owners representative for the owners files.
- 18.7 Give a copy of the completed drop test form** to the owners representative for the owners files and maintain a copy for your records.

19.0 MAINTENANCE

- 19.1 Inspect assemblies for cleanliness, fit and operation monthly.
- 19.2 Inspect guides, curtain and hood for wear or visible damage. Report any unusual wear or damage for immediate repair.
- 19.3 Inspect all fasteners for tightness and for damage. Report any damage or loose fasteners immediately for repair.
- 19.4 Inspect guides for unusual accumulations of dirt, grease or foreign matter that would hinder normal operation or drop procedure.
- 19.5 Inspect fusible links, cables and release devices for dust, grease or foreign materials that may impede release or operation.
- 19.6 Immediately report and replace any fusible links that have grease, paint or foreign materials that will prevent separation.
- 19.7 NFPA-80 and other code bodies recommend annual drop testing. Drop testing is an important part of any maintenance program.

- ☑ **WARNING!! Wear protective gloves and eye wear when working on assemblies.**
- ☑ **WARNING!! If in doubt of the fitness or structural integrity of jambs, a qualified engineer must inspect the must conditions.**
- ☑ **WARNING!! Guides are not intended or designed to act as structural reinforcement for existing jambs.**
- ☑ **WARNING!! Installation of anchoring devices into unsound building material will result in product damage, personal injury, premature wear and product failure.**
- ☑ **WARNING!! Secure all loads to hoist equipment to prevent movement while hoisting. Do not allow personnel to ride hoist equipment. Stay off ladders and lifts until barrel and/or curtain have been hoisted to the final position of attachment. Serious personal injury will result from carelessness or lack of planning. Plan all moves carefully!**
- ☑ **WARNING!! It is essential that you use hoisting equipment of adequate stability and rated capacity.**
- ☑ **WARNING!! Never exceed the number of preload turns shown.**
- ☑ **WARNING!! Before drop testing curtain be certain opening is in sight and clear of people and obstructions.**
- ☑ **WARNING!! Spring is under tension and extremely dangerous. Adjustments should be performed only by experienced door technicians who have the proper tools, instructions and a thorough understanding of the entire assembly and its operation.**
- ☑ **WARNING!! Never place fingers near any moving parts while door is in operation.**
- ☑ **WARNING!! Adjustments or repairs to installation should be performed only by mechanically experienced door technicians who have the proper tools, instructions and a thorough understanding of the entire assembly and its operation.**

20.0 PAINTING

- 20.1 Curtain slats and hood feature finish coat polyester paint over baked on enamel primer and galvanized steel. Protective paint coats are not necessary unless desired. Guides and end brackets are factory coated with high quality primer which is compatible with most quality exterior grade paints.
- 20.2 FIELD PAINTING: Wash surface thoroughly with a solution of trisodium phosphate (commonly called TSP). Buff surface lightly with an extra-fine-grade steel wool. Repair any rust or bare metal areas and coat with a zinc-based primer. Paint with premium-quality oil-based or latex exterior paint. Avoid use of solvents (mineral spirits can be used). Apply paint to small area of door to test for adhesion. If new paint does not chip, crack or bubble, apply to remainder of door. If in doubt about the correct paint system to use, contact a painting professional.

🚩 **WARNING!! Do not Paint:**

- 🚩 Axles, bearings or moving parts
- 🚩 Wear surfaces on guides
- 🚩 Stainless steel slide locks
- 🚩 Bottom bar angles
- 🚩 Brush seal, jamb seal or bottom astragal
- 🚩 Safety warning labels
- 🚩 Operational labels or placards
- 🚩 Fusible links
- 🚩 Cables

- 19.3 ASTA recommends that you closely follow paint manufacturer's recommendations for cleaning, preparing and applying paint to obtain best results.

ASTA WARRANTY

ASTA Door Corporation, warrants each rolling steel door and components to be free from defects in materials and workmanship for a period of five years from the date of receipt to the original purchaser. Specific exclusions apply as follows: Dents, scratches, paint wear, component wear or any damage incurred from handling, installation or normal operation is beyond control of the factory and specifically excluded herein. Spring wire is warranted for one year from date of receipt to original purchaser. ASTA reserves the right to inspect any assembly or part alleged to be defective and to refuse the return of any materials unless the return is expressly authorized by ASTA. Liability to ASTA is limited hereunder to the replacement of any part found to be defective and does not include labor charges for dismantle, repair or re-assembly. ASTA shall not be liable for any consequential, incidental or collateral damages. All other warranties, expressed or implied, including any warranties of merchantability are hereby expressly excluded.

TROUBLE SHOOTING

PROBLEM	PROBABLE CAUSE	REMEDY
<input checked="" type="checkbox"/> Curtain will not close all the way to the counter.	Too much spring preload.	Open curtain fully and back tension off one hole at a time until satisfactory balance is achieved (Page 13).
<input checked="" type="checkbox"/> Curtain will not stay shut.		
<input checked="" type="checkbox"/> Curtain closes hard.		
<input checked="" type="checkbox"/> Curtain closes too fast.	Too little spring preload.	Open curtain fully and increase tension one hole at a time until satisfactory balance is achieved (Page 13).
<input checked="" type="checkbox"/> Curtain runs to one side.	Barrel not level.	Refer to Barrel Assembly Installation. Barrel must be level (Page 10).
	Curtain not centered.	Refer to Curtain Installation (Page 11).
<input checked="" type="checkbox"/> Curtain is hard to move in either direction.	Hood Damaged	Verify that you have held the "X" dimension full height of guides (Page 3).
	Guides damaged.	Check for bent or damaged guides. Slats not centered in guides and headplates (Page 11).
	Key stock dragging	Verify that guide gap for curtain was set at correct width (Page 12).
<input checked="" type="checkbox"/> Curtain "jumps" on way down or up.	Curtain binding on headplate or guides.	Check for bent or damaged guides.
		Check that "X" dimension has been held at headplates (Page 3).
		Slats not centered in guides and headplates (page 11).
<input checked="" type="checkbox"/> Curtain difficult to raise, will not stay open at head.	Broken spring.	Contact qualified ASTA Door technician to evaluate.

To insure proper identification of this door please complete the information below.

Door Model: _____ Door Size: _____ x _____

Installed By: _____

Installation Date: _____



ASTAAMERICA

BY JANUS INTERNATIONAL