



**ASTA AMERICA**

BY JANUS INTERNATIONAL

WINDLOCK  
SHEET DOOR  
**203**

### ASTA AMERICA 203 SERIES

continuous corrugated **Windlock Sheet Door** is produced with the highest quality and durability in the industry. The **203 Series** is available in sizes up to 20' x 18' in a variety of colors. Excellent price and efficient installation makes the **203 series** the perfect choice for loading docks, warehouse buildings, distribution centers, freight terminals, or any commercial applications with high windload requirements. The **203 Series** is windload certified and tested to approved standards as specified in the Florida and Texas Building Codes. Impact Doors are also available.



### OPTIONS

**Steel Mounting Plates:** For lateral jamb extension to provide door support.

**Electric Operation:** Easy, fast motorized operation at a push of a button.

**Top Draft Seal:** To seal tight at the header to reduce air filtration (standard Model 204).

**Insulation:** Refer to ASTA AMERICA Model 204 - standard 203 design with mylar and polyethylene insulation laminated to backside of curtain.

**Side Draft Seal:** 2" brush weatherseal with 1" aluminum retainer attached to door jamb field installed (standard on Model 204).

# WINDLOCK SHEET DOOR 203

**Windload** | Door construction designed to satisfy windload of +30/-34 PSF up to 16' wide, based on ANSI/DASMA -108/115 test method to meet Florida Building Code requirements. Available up to 20' wide. Impact rated doors available up to 16' wide with +42.5/-45 PSF windload rating.

**Hardware** | For mounting to steel or block/masonry jambs (specify when ordering).

**Drum/Axle Assembly** | 12" diameter galvanized steel spiral torque tube attached to 16-gauge galvanized drums, supported by 1 5/16" O.D. steel tubing. All drums are fitted with grease filled, shielded radial ball bearing for smoother operation, reduced friction and wear.

**Curtain** | The 26-gauge corrugated door curtain is manufactured from full hard galvanized grade 80 steel and coated with Super Durable polyester paint that is backed by a 40-year film integrity and 25 year no-fade limited paint warranty. 12-gauge galvanized windlock clips are riveted to the curtain edge to engage the 12-gauge windlock insert within the door guide.

**Locks** | Dual galvanized steel slide bolt locks attached to the bottom bar suitable for padlocks (padlocks by other).

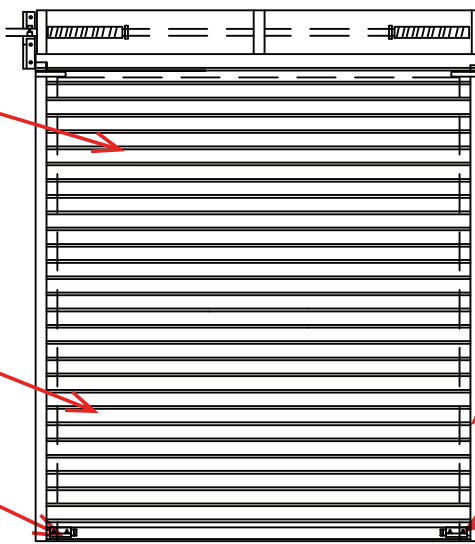

**Operation** | Reduction gear chain hoist standard for all size.

**Guides** | To be roll formed 12-gauge galvanized steel channels with toggle locked 12-gauge windlock insert.

**Bottom Bar** | 2" x 1-1/2" x 12-gauge galvanized angle fastened to roll-formed steel bottom bar with PVC bulb astragal.

## SPECIFICATION DETAIL

### Clearance Requirements

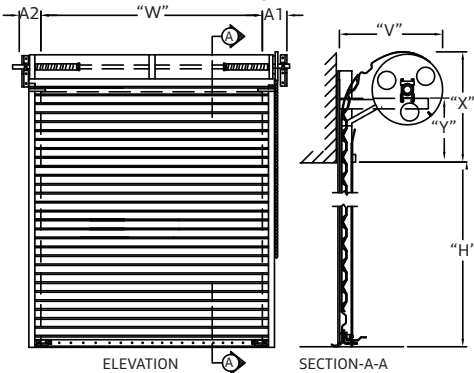

Clearance Requirements For Model 203 Windlock Sheet Door						
	Height	A-1	A-2	X	Y	V
Manual Push Up	Up to 8'	7 1/2"	7 1/2"	20"	9 1/2"	20"
Manual Push Up	Up to 10'	7 1/2"	7 1/2"	21"	10"	21"
Chain Hoist or Electric Operator	Up to 8'	7 1/2"	10 1/2"	20"	10"	20"
	Up to 10'	7 1/2"	10 1/2"	21"	11"	21"
	Up to 16'	7 1/2"	10 1/2"	23"	11"	24"
	Up to 18'	8 1/2"	11 1/2"	24"	12"	24"

Dimensions do not include the operator itself

### Model 203 Wind Load Chart (Maximum Door Height 18'-0")

Maximum Door Width	Design Load (+/- PSF)	FL Approval #	TX Approval #
8'-0"	+58.5 / -66.3	FL21450	FL21450
9'-0"	+52.3 / -59.3	FL21450	FL21450
10'-0"	+47.2 / -53.6	FL21450	FL21450
12'-0"	+39.6 / -44.9	FL21450	FL21450
14'-0"	+34.1 / -38.7	FL21450	FL21450
16'-0"	+30.0 / -34.0	FL21450	FL21450
18'-0"	+24.6 / -27.9	FL21450	FL21450
20'-0"	+20.9 / -23.7	FL21450	FL21450

### Model 203 Impact Rated Door (Maximum Door Height 18'-0")

Thru 16'-0"	+42.5 / -45.0	FL21450	FL21450
-------------	---------------	---------	---------

### Filled Block Jambs LH Guide Mount Shown OPTION 2

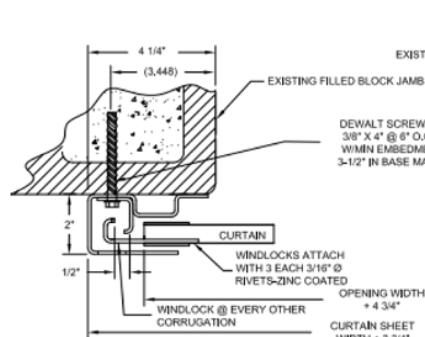

### Concrete Jambs RH Guide Mount Shown OPTION 2

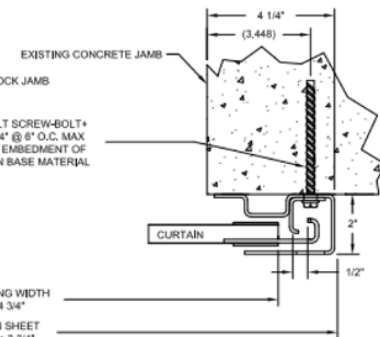

### Steel Jambs LH Guide Mount Shown OPTION 3

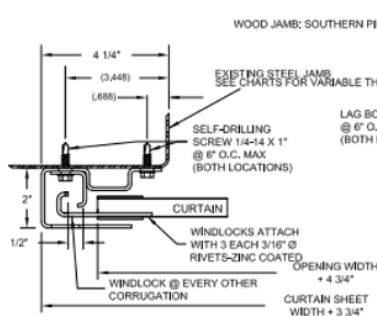

### Wood Jambs RH Guide Mount Shown OPTION 2

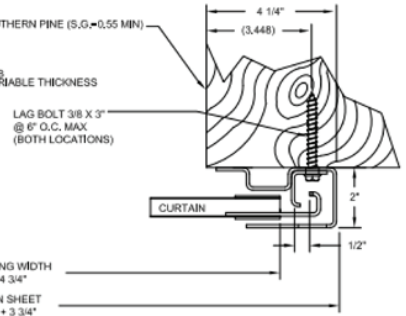

ASTA AMERICA reserves the right to change engineering specs. without prior notice. Illustrations shown are for general reference and should be verified for construction purposes. Consult customer service for technical support.

2024/03