

GENERAL NOTES:

1. OPERATION TYPE MAY BE PUSH-UP, HAND CHAIN OR ELECTRIC.
2. FOR CRITICAL FITS DUE TO REDUCED AVAILABLE HEADROOM OR SIDEROOM CLEARANCES, CONSULT FACTORY.
3. CLEARANCES SHOWN ARE MAXIMUMS. LESSER CLEARANCES MAY BE POSSIBLE.
4. UNLESS OTHERWISE NOTED, DOORS SHALL BE PROVIDED WITH SLIDE LOCKS AT EACH END OF BOTTOM BAR, ENGAGING GUIDES IN THE LOCKED POSITION.
5. SERIES 202 IS AN INSULATED SERIES 201.
6. ALL OPENING PREPARATION, ELECTRICAL POWER AND FIELD PAINTING SHALL BE PROVIDED BY OTHERS.
7. CURTAIN FINISH SHALL BE SILICONE POLYESTER PRE-PAIN OVER GALVANIZED GRADE 80 STEEL.
8. VISION PANELS ARE AVAILABLE.
9. MAXIMUM OPEN SIZE: 12'-0" X 16'-0"

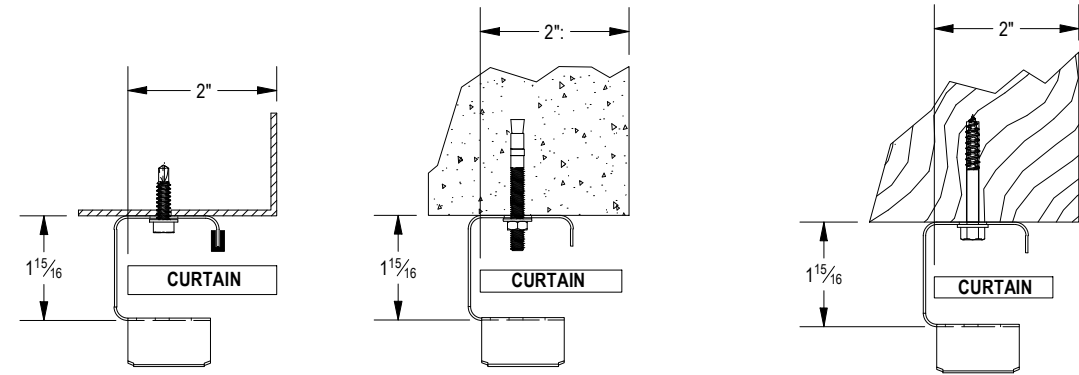
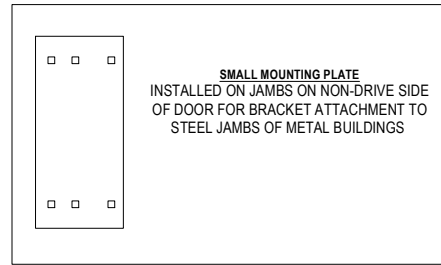
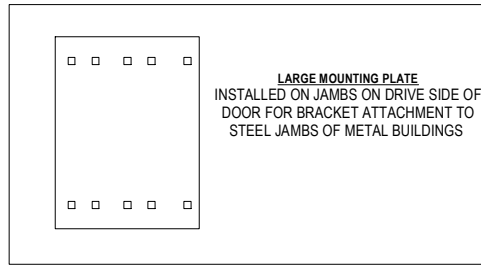

(*) FOR PUSH-UP OPERATION.....5"
 FOR HAND CHAIN OPERATION.....8 1/2"
 FOR ELECTRIC OPERATION.....8 1/2"
 FOR ATA OPERATION.....6 1/2"

BRACKET ATTACHMENT

STEEL JAMBS: 3/8" - 16 X 1 1/4" HEX BOLT AND NUT.
 CONCRETE/MASONRY JAMBS: 3/8" X 4" WEDGE BOLT.
 WOOD JAMBS: 3/8" X 3" LAG SCREW.

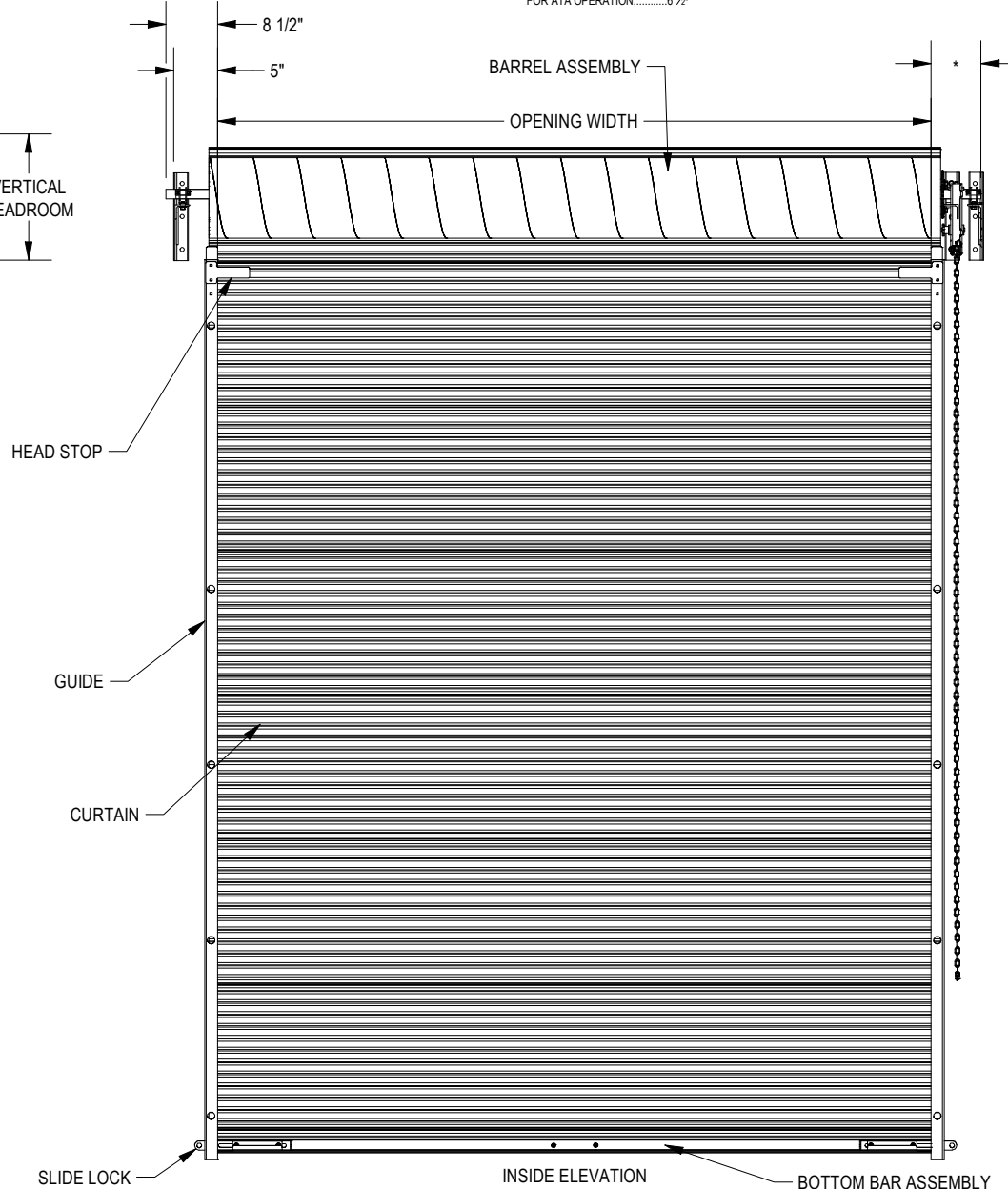
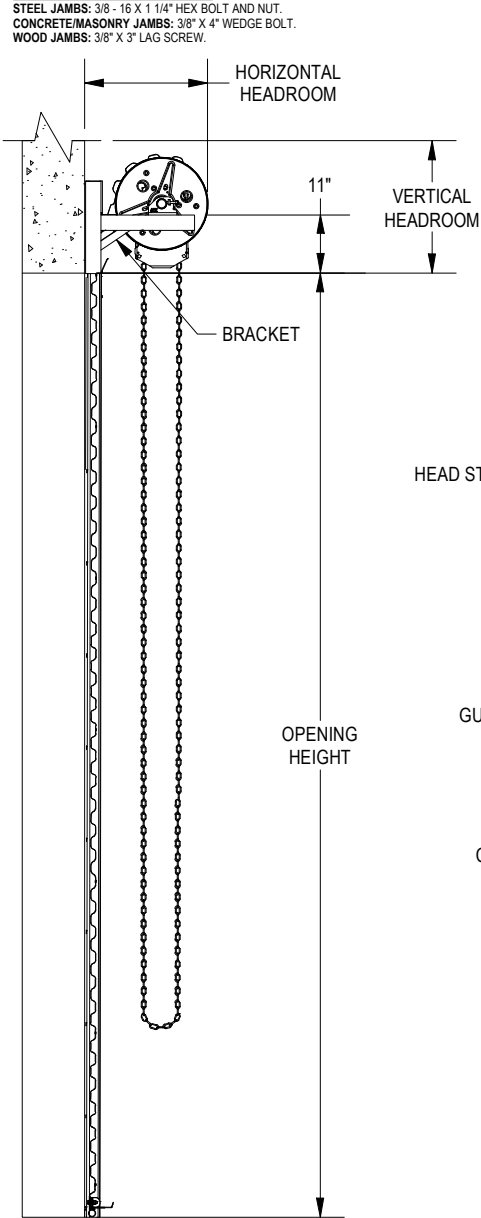

HEADROOM REQUIREMENT		
OPENING HEIGHT	VERTICAL HEADROOM	HORIZONTAL HEADROOM
THRU 8'-0"	19"	20"
THRU 10'-0"	21"	21"
THRU 14'-0"	23"	23"
THRU 16'-0"	24"	24"

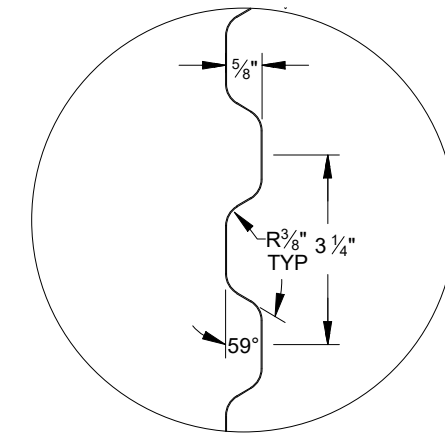

DETAIL A

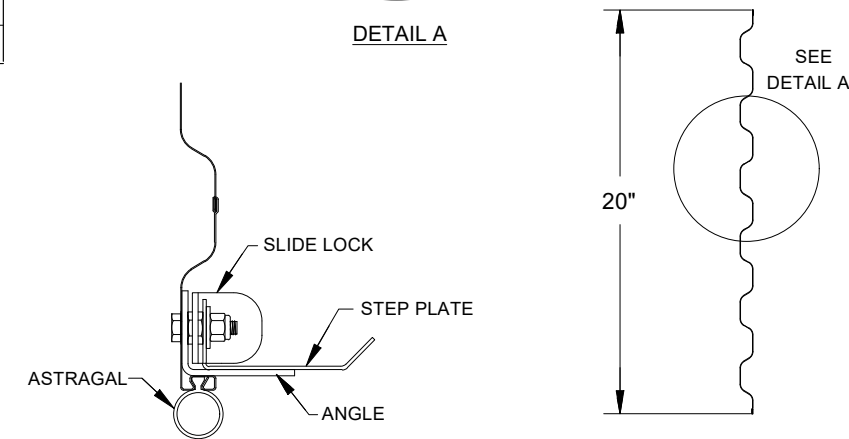

BOTTOM BAR ASSEMBLY

26 GA CURTAIN PANEL DETAIL

814003-0001

5/01/2023

COMMERCIAL DOOR: 201/202

CUSTOMER NUMBER:		DATE:	
CUSTOMER NAME:		CONTACT:	
PROJECT NAME:			
PROJECT LOCATION:			
PLANT:		SALESPERSON:	
DRAWN BY:		DRAWN BY DATE:	
DRAWING NUMBER:		SHT:	OF:

FACTORY ORDER NUMBER	DOOR SERIES	QTY	OPENING SIZE		JAMB TYPE			OUTSIDE CURTAIN COLOR	OPERATION			OPERATION HAND	WEATHERSTRIP			ADDED OPTIONS
			WIDTH	HEIGHT	STEEL	CONC./ MAS	WOOD		PUSH UP	REDUCED CHAIN	ELECTRIC		TOP	HEADER	SIDE	

NOTES:

