

**GENERAL NOTES:**

- OPERATION TYPE MAY BE PUSH-UP, HAND CHAIN OR ELECTRIC.
- FOR CRITICAL FITS DUE TO REDUCED AVAILABLE HEADROOM OR SIDEROOM CLEARANCES, CONSULT FACTORY.
- CLEARANCES SHOWN ARE MAXIMUMS. LESSER CLEARANCES MAY BE POSSIBLE.
- UNLESS OTHERWISE NOTED, DOORS SHALL BE PROVIDED WITH SLIDE LOCKS AT EACH END OF BOTTOM BAR, ENGAGING GUIDES IN THE LOCKED POSITION.
- ALL OPENING PREPARATION, ELECTRICAL POWER AND FIELD PAINTING SHALL BE PROVIDED BY OTHERS.
- SERIES 204IM IS AN INSULATED SERIES 203IM
- CURTAIN FINISH SHALL BE SILICONE POLYESTER PRE-PAIN OVER GALVANIZED GRADE 80 STEEL.
- MODEL 203IM IS A STATE OF FLORIDA APPROVED WINDLOAD PRODUCT. PRODUCT EVALUATIONS AND STAMPED DRAWINGS ARE ACCESSIBLE VIA [www.floridabuilding.org](http://www.floridabuilding.org). FL#21450
- MODEL 203 IS EVALUATED FOR COMPLIANCE THROUGH TEXAS DEPARTMENT OF INSURANCE (TDI). PRODUCT EVALUATIONS AND STAMPED DRAWINGS ARE ACCESSIBLE VIA [www.tdi.texas.gov](http://www.tdi.texas.gov)
- PLEASE NOTE: STANDARD GUIDE MANUFACTURING METHOD FOR STEEL JAMBS PER MOUNTING OPTION 1.
- MAXIMUM OPEN SIZE: 20'-0" X 18'-0"

**BRACKET ATTACHMENT**

STEEL JAMBS: 3/8" - 16 X 1 1/4" HEX BOLT AND NUT.  
 CONCRETE/MASONRY JAMBS: 3/8" X 4" DEWALT WEDGE BOLT + SCREW ANCHORS  
 WOOD JAMBS: 3/8" X 3" LAG SCREW.

(\*) FOR PUSH-UP OPERATION.....6 3/4"  
 FOR HAND CHAIN OPERATION.....6 3/4"  
 FOR ELECTRIC OPERATION.....7 1/4"  
 FOR OUTSIDE OF CHAIN DRIVE.....8 3/4"

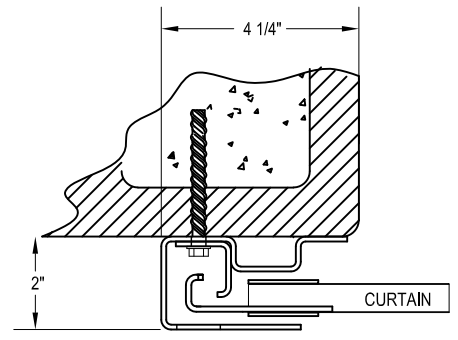
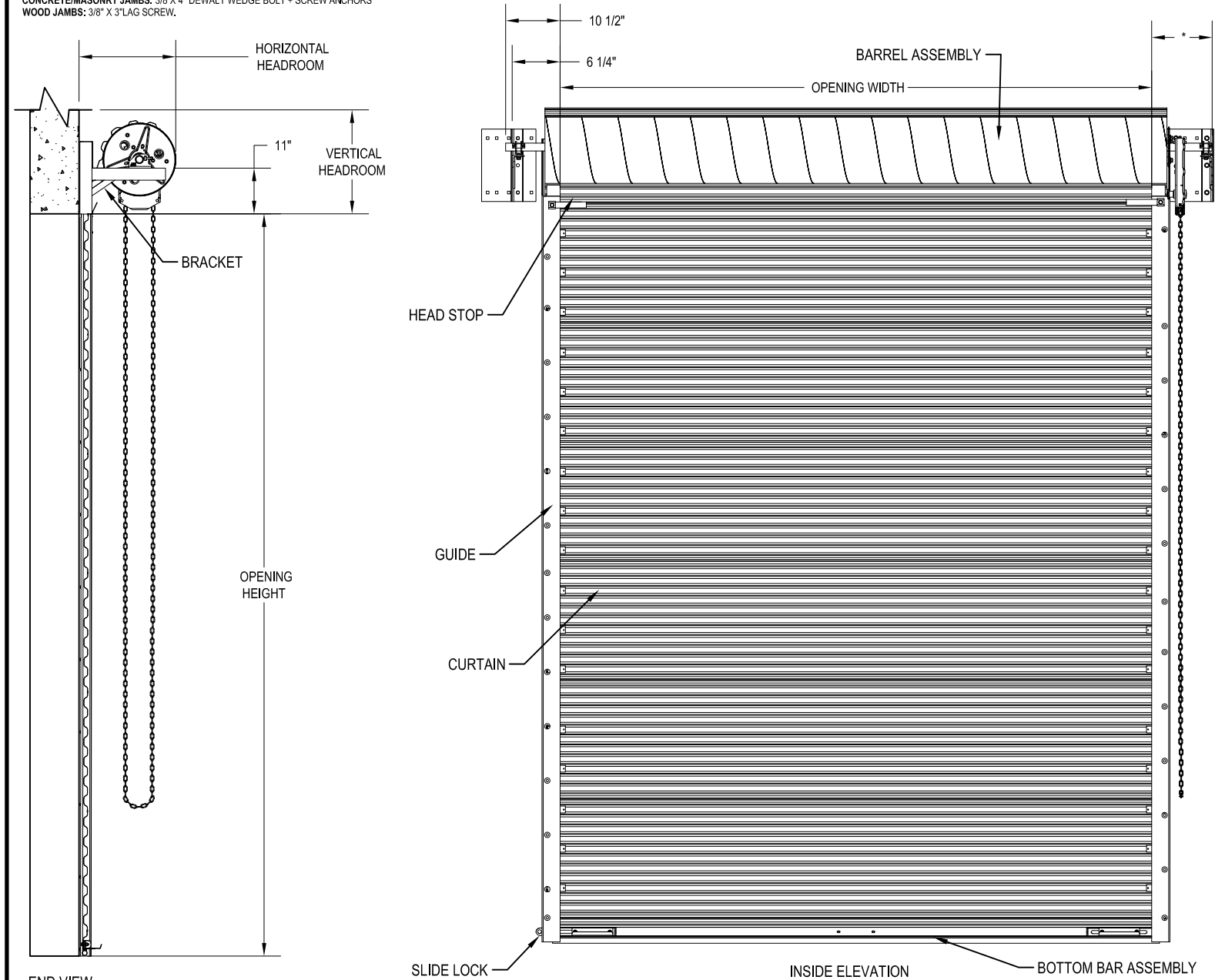

**CONCRETE FILLED JAMB:**  
 (OPTION 2)  
 3/8" x 4" DEWALT WEDGE BOLT + SCREW ANCHORS

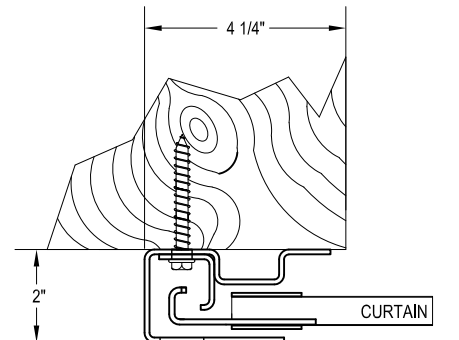

**WOOD JAMB:**  
 (OPTION 2)  
 3/8" X 3" LAG BOLTS

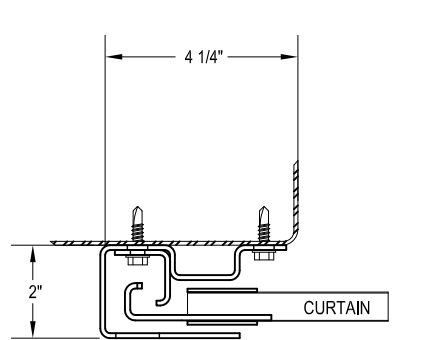

**STEEL JAMB (OPTION 3)**  
 STEEL JAMBS USING  
 1/4" - 14 X 1" SELF DRILLING SCREW

HEADROOM REQUIREMENT		
OPENING HEIGHT	VERTICAL HEADROOM	HORIZONTAL HEADROOM
THRU 8'-0"	19"	20"
THRU 10'-0"	21"	21"
THRU 14'-0"	23"	23"
THRU 16'-0"	24"	24"
THRU 18'-0"	25"	25"

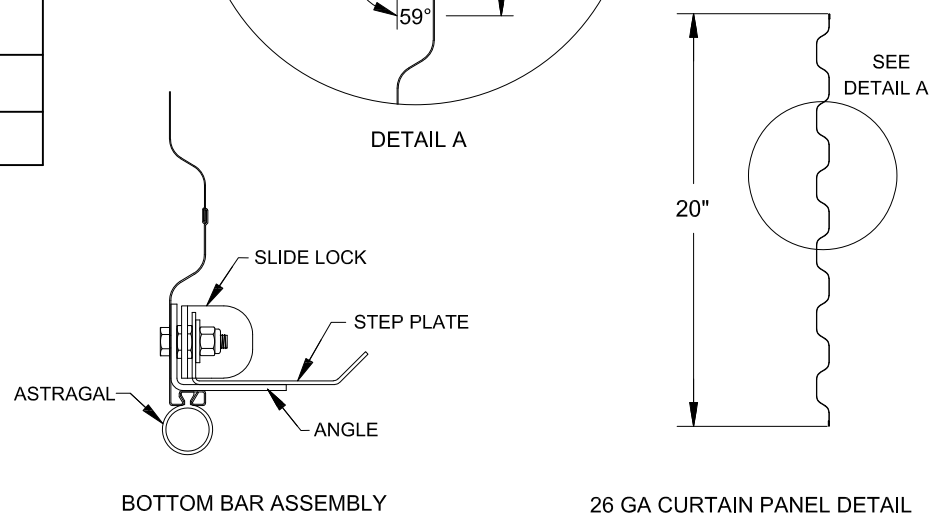
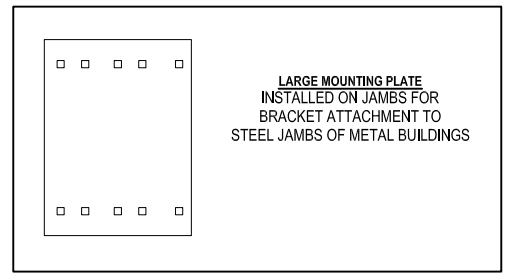
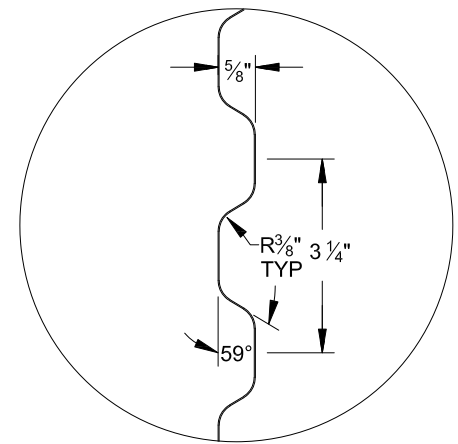

FACTORY ORDER NUMBER	DOOR SERIES	QTY	OPENING SIZE		JAMB TYPE			OUTSIDE CURTAIN COLOR	OPERATION			OUTSIDE CURTAIN COLOR	WEATHERSTRIP			ADDED OPTIONS
			WIDTH	HEIGHT	STEEL	CONC./MAS	WOOD		PUSH UP	HAND CHAIN	ELECTRIC		TOP	HEADER	SIDE	

NOTES:

DRAWING NUMBER: 814009-0002 DATE: 12/13/2023

## COMMERCIAL DOOR SERIES: 203IM/204IM

CUSTOMER NUMBER:		DATE:
CUSTOMER NAME:		CONTACT:
PROJECT NAME:		
PROJECT LOCATION:		
PLANT:		SALESPERSON:
DRAWN BY:		DRAWN BY DATE:
DRAWING NUMBER:		SHT: OF:

